

Rapid Detection Techniques Useful for Primary Indicators of  
Activated Sludge Treatment Optimization

Amber M. Boone

Johns Hopkins University

Master's Thesis – Spring 2007

With Support from the Santa Margarita Water District  
and the University of California, Irvine

## Table of Contents

	Page #
<b>List of Equations, Figures, and Tables</b>	3
<b>Abstract</b>	4
<b>Introduction</b>	4
<b>Materials and Methods</b>	12
a) Sewage Treatment Plant Diagrams, Descriptions, and Sample Locations	12
b) Physical and Chemical Tests	13
i. Physical Tests	13
ii. Nitrogen Series of Tests	13
iii. Other Tests	13
c) DNA extraction	14
i. Bead Beating Experiment	14
ii. Sample Holding Time Experiment	15
d) Purity of DNA Extracted	15
e) Primer & Probe Selection	15
f) qPCR Assay	16
g) Ammonia-Oxidation per cell per hour	16
h) Gel Electrophoresis and Visualization	17
i) Operating Parameters	17
i. Solids Retention Time	17
ii. Food to Mass Ratio	17
iii. Minimum Solids Retention Time	18
iv. Organic Loading	18
v. Detention Time	18
j) Data Analysis	19
i. Parametric Statistics	19
ii. Normalization of Data	19
<b>Results</b>	20
a) Sample Location – t-test	20
b) Analytical and Operating Parameters at CWRP & OCWRP	21
c) DNA extraction	21
i. Bead Beating Analysis	21
ii. Sample Holding Time Analysis	22
d) Ammonia Oxidation per cell per hour Results	22
e) Gel Picture	23
f) Total Bacteria & AOB Cell Numbers	24
i. CWRP Results	24
ii. OCWRP Results	25
g) Correlation Results – Including Applicable Figures	26
<b>Discussion</b>	37
<b>Conclusion</b>	42
<b>Acknowledgements</b>	42
<b>Works Cited</b>	43

## **List of Equations, Figures, and Tables:**

Equation 1: Deamination and Hydrolysis of Urea  
Equation 2: Oxidative Deamination  
Equation 3: Reductive Deamination  
Equation 4: Nitrification Reaction  
Equation 5: Ammonia Oxidation per cell per hour  
Equation 6: Solids Retention Time (SRT)  
Equation 7: Food to Mass Ratio (f/m)  
Equation 8: Minimum Solids Retention Time (SRT)  
Equation 9: Organic Loading  
Equation 10: Detention Time (DT)  
Equation 11: Copies per reaction back to rehydration volume  
Equation 12: Cells/L  
Equation 13: Adjusting for copy numbers

Figure 1: Process Flow Diagram for the Chiquita Water Reclamation Plant  
Figure 2: Process Flow Diagram for the Oso Creek Water Reclamation Plant  
Figure 3: Representation of the Percent Difference in No Second Bead Beating  
Figure 4: Picture of Gel Using *Nitrosomonas Europea* primers and probes  
Figure 5: Total Bacteria vs. Total AOB at CWRP  
Figure 6: Percent AOB at CWRP over Experiment Period  
Figure 7: Total Bacteria vs. Total AOB at OCWRP  
Figure 8: Percent AOB at CWRP over Experiment Period  
Figure 9: MLSS as it relates to AOB Cells/L at CWRP  
Figure 10: Total Bacteria and Total AOB vs. D.O. Requirement at CWRP  
Figure 11: RAS as it relates to AOB Cell/L at CWRP  
Figure 12: Total Influent BOD as it Relates to AOB Cells/L at CWRP  
Figure 13: Total Effluent BOD as it Relates to AOB Cells/L at CWRP  
Figure 14: Ammonia Removal as it Relates to AOB Cells/L at CWRP  
Figure 15: The relationship between the percent of ammonia removed and AOB concentration at CWRP  
Figure 16: Effluent Nitrate Concentration as it Relates to AOB Cells/L  
Figure 17: Detention Time as a Function of AOB Cells/L at CWRP  
Figure 18: Organic Loading as it Relates to AOB Cells/L at CWRP  
Figure 19: Secondary Effluent Turbidity as it Relates to AOB Cells/L at CWRP  
Figure 20: Flow (MGD) as it Relates to AOB at OCWRP  
Figure 21: Ammonia Oxidation per cell per hour as a Function of AOB Cells/L at OCWRP  
Figure 22: Effluent Nitrite Concentration as a function of AOB Cells/L at OCWRP  
Figure 23: Detention Time as a Function of AOB Cells/L at OCWRP  
Figure 24: AOB Cells/L as a Function of Increased Secondary Turbidity at OCWRP  
Figure 25: Operator Recorded SCFM as it Relates to AOB Cells/L and D.O.  
Figure 26: The relationship between SCFM, KW, and D.O.  
Figure 27: AOB Cells/L as a function of D.O. and the Cost of Aeration Blowers

Table 1: Primers and Probes Used  
Table 2: Sample Location Justification – Student’s t-test  
Table 3: Average Operating and Analytical Parameters  
Table 4: Comparison of DNA Purity Ratio and the % DNA Yield  
Table 5: Analysis of Limpiyakorn Method  
Table 6: Statistical Correlation between Independent and Dependent Variables  
Table 7: Optimization Variables at CWRP  
Table 8: Optimization Variables at OCWRP

## **Abstract**

The aim of this project is to deduce the practical application of incorporating quantitative polymerase chain reaction (qPCR) as a predictive tool of effluent water quality as a measure of ammonia oxidizing bacteria (AOB) within the *Betaproteobacteria* class versus total bacteria cell numbers (cells/L) in two incomplete nitrification treatment plants in Southern California. The 16S rRNA regions of both groups of bacteria were the targeted gene sequence used to deduce cell numbers. Previous researchers have related total bacterial and AOB cell numbers to various operating and analytical parameters, but have not shown a direct correlation between secondary effluent water quality and bacterial cell numbers in the aeration basin of nitrifying activated sludge plants. A strong positive relationship was found between the number of AOB cells and secondary effluent quality as measured by turbidity (ntu) at both treatment plants in this study, thereby demonstrating the practical aspect of utilizing the qPCR technique as a predictor of secondary effluent water quality. It is interesting to note that total bacteria had a lower correlation coefficient than AOB providing insight into the pivotal role the AOB play in the production of recycled water.

## **Introduction**

The arid West necessitates a mixture of water management strategies employed by local leaders in order to avoid water shortages in their respective regions. One key strategy is recycling water to meet increasing demand. Wastewater treatment plants are recycling incoming flows by reducing the nutrient-rich water to acceptable permit levels with the aid of microorganisms. One key group of microorganisms is the ammonia oxidizing bacteria (AOB) that reduce ammonia concentrations in the wastewater by converting that ammonia to nitrite with the aid of molecular oxygen. Another group of bacteria, the nitrite oxidizing bacteria (NOB), further convert the nitrite produced from the AOB to nitrate, also with the aid of molecular oxygen. This two-step conversion results in a reduction in the environmental load of nitrogen to receiving water bodies. AOB represent the rate-limiting step in the conversion of ammonia and are thus the main group of microorganisms that this study will focus on. In the past the AOB have not been used industry wide for the control of the secondary treatment process, since these bacteria are difficult and tedious to culture and enumerate.

New rapid detection methods that use molecular techniques are emerging to circumvent the long culturing periods necessary for the AOB to grow and avoid the selection bias for certain genera imposed by media. The main focus of this project is to determine relationships between the number of AOB responsible for ammonia conversion and operational parameters in the aeration basin of the secondary treatment process. If strong relationships among operating parameters and molecular quantitation of the population are found, then manipulation of certain operating parameters can be used to optimize process performance of ammonia oxidation and thereby improve the production of recycled water. The operational controls that will be evaluated are mixed liquor suspended solids (MLSS), mixed liquor volatile suspended solids (MLVSS), dissolved

oxygen (D.O.) concentrations, return activated sludge flow, wasting rate, average incoming flow, food to mass ratio (f/m), detention time (DT), and the required solids retention time (SRT) to prevent washout of the microorganisms versus the actual SRT. The analytical parameters that will be measured in this project include alkalinity removal, ammonia removal, nitrite-nitrogen, nitrate-nitrogen, total BOD removal, pH, temperature, and influent vs. effluent MLSS and MLVSS. The results of this project will allow the management of the Santa Margarita Water District in their decision to invest further in quantitative polymerase chain reaction instruments and reagents to better optimize the treatment of wastewater.

From 1800 to present, urban wastewater management has shifted from decentralized to centralized treatment locations and management. The value of wastewater has changed from a nuisance waste stream to a resource that should be adequately treated and reclaimed (Burian, 2000). The first federal act to begin comprehensive planning, technical services, financial assistance, and enforcement was the Federal Pollution Control Act of 1948. Through succeeding amendments one goal of the 1965 legislation was to “enhance quality and value of the water resources of the United States (US)”(Burian, 2000). This explicit goal set the stage for modern wastewater management.

The 1972 Federal Water Pollution Control Act (FWPCA, 1972), provided the impetus to control point and non-point sources of pollution entering into the nation’s waterways. Through subsequent amendments in 1977 and reauthorization in 1987, this act became known as the Clean Water Act (CWA) and required, among other things, that funding be made available to construct sewage treatment facilities to control point sources of pollution. The amendments also established certain water quality standards (WQS) that would provide quantifiable limitations for the CWA set of goals. These WQS formed the foundation for limitations established in permit requirements, titled the National Pollutant Discharge Elimination System (NPDES), for any facility that discharged point sources of pollution, namely wastewater treatment plants, into any receiving water body. Title II, section 201, subsection (3d) (FWPCA-b, 1972) of the CWA indicates the federal government’s support of “waste treatment which results in the construction of revenue producing facilities for...the reclamation of wastewater.”

As the CWA inspired better management of water resources at the federal level, states began implementing action plans of their own even before the 1972 CWA amendment to control point and non-point sources of pollution. Specifically in California the Porter-Cologne Water Quality Act (P-CWA) of 1969 (Water Pollution Control Legislation, 2003) became the principal law governing water quality in California. In particular it designated the State Water Resource Control Board (SWQCB) and nine Regional Water Quality Control Boards (RWQCBs) to be in charge of managing water quality in California. Water Quality Control Plans (WQCPs) have been the acceptable means to achieve the goals of the P-CWA in each respective regional division.

Each RWQCB regulate wastewater treatment plant dischargers in their region by issuing waste discharge requirements (WDRs) in the form of NPDES permits and other

applicable legislative orders that require the discharger to meet the water quality guidelines consistent with each respective WQCP or face punitive damages.

In 1985 the Santa Margarita Water District (SMWD) broke ground on the Chiquita Water Reclamation Plant (CWRP). In 2001, the District began construction of a recycled water component at CWRP to meet growing water demands in Southern Orange County. The Oso Creek Water Reclamation Plant (OCWRP), another treatment plant under the SMWD's jurisdiction, also is producing recycled water to meet increasing demand. By recycling wastewater into usable water for irrigation purposes, SMWD is meeting the policy objectives of the CWA and P-CWA while also increasing water reliability and reducing rising costs for imported water. Secondary and tertiary systems are now producing approximately five million gallons per day (MGD) of reclaimed water per day at CWRP and approximately 2.5 MGD at OCWRP. The CWRP is projected to produce up to thirteen million gallons per day.

The water reclaimed at CWRP and OCWRP fall under Region 9 RWQCB Order 97-52: Waste Discharge and Water Recycling Requirements for the Production and Purveyance of Recycled Water by Member Agencies of the South Orange County Reclamation Authority, Orange County. The California Water Code under Section 13263 requires Region 9 RWQCB to establish these WDR since the CWRP and OCWRP recycled water could affect water quality in this region. Also, given that the P-CWA controls not only surface water and groundwater flow (Water Pollution Control Legislation, 2003), the WQCP for Region 9 (as required by the act) must take into consideration both of these water flows when establishing guidelines for permit requirements issued to point source discharges.

Since groundwater can be affected by the seepage of irrigation water from recycled water, the Region 9 WQCP mandates limits of 10 mg/L of NO<sub>3</sub>-N (nitrate as nitrogen), 10 mg/L NO<sub>3</sub>-N + NO<sub>2</sub>-N (nitrate as nitrogen plus nitrite as nitrogen), and 1 mg/L NO<sub>2</sub>-N (nitrite as nitrogen), which are consistent with the EPA's Maximum Contaminant Levels (MCL) in drinking water supplies (EPA, 2006). The public health concern in drinking water stems from "Blue-Baby Syndrome" (methemoglobinemia), a malady that affects babies who are exposed to high nitrate levels in drinking water supplies. The prescribed limits of 10mg/L of NO<sub>3</sub>-N are based on the result of toxicological studies that determined that below the established MCL, Blue-Baby Syndrome did not occur (NAS, 1995). The AOB convert ammonia to nitrite only, and since nitrite is not readily accumulated, ammonia oxidation is thus the rate-limiting step in the nitrification reaction in the aeration basin.

The food source that AOB require is ammonia-nitrogen (Suzuki, 1974) and the origin of this substrate is mainly from urea and proteins. The needed chemical reactions that transform the incoming wastewater into ammonia-nitrogen for the AOBs, occur in 90% of the incoming wastewater by the time the wastewater enters into a treatment plant (Culp *et al.* 1978).

Urea is deaminated and then hydrolysed by the enzyme urease (Equation 1-Gray, 2004).

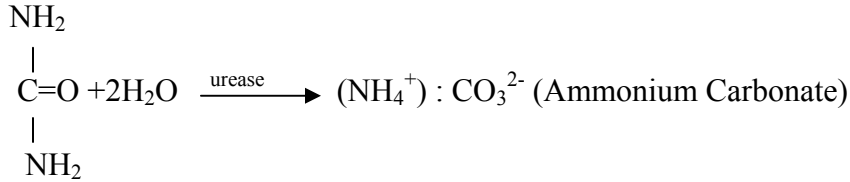

Equation 1: Deamination and hydrolysis of urea

Proteins are also broken down into peptides and amino acids by extracellular proteolytic enzymes. Protease is the enzyme responsible for the catabolic reaction whereby the hydrolysis of peptide bonds linking amino acids are broken down. The amino acids are broken down by either oxidative deamination (equation 2 – Gray, 2004) or reductive deamination (equation 3 – Gray, 2004).

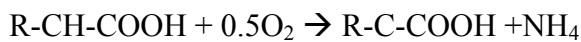

Equation 2: Oxidative Deamination

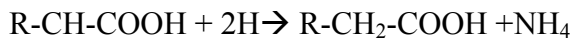

Equation 3: Reductive Deamination

AOB are obligate chemolithotrophic autotrophs and need not only ammonia, but also dissolved oxygen for cell maintenance and reproduction. The oxidation of ammonia to nitrite generally represents a two-step process (Suzuki, 1984; Hooper, 1984; Wood, 1986):

- 1)  $\text{NH}_3 + 2[\text{H}] + \text{O}_2 \rightarrow \text{NH}_2\text{OH} + \text{H}_2\text{O}$
- 2)  $\text{NH}_2\text{OH} + \text{H}_2\text{O} \rightarrow \text{HNO}_2 + 4\text{H}^+ + 4\text{e}^-$

Equation 4: Nitrification Reaction

The first step in ammonia-oxidation requires the integral membrane enzyme ammonia monooxygenase (AMO) (Sayavedra-Soto, 1998). The second step is accomplished with the enzyme hydroxylamine oxidoreductase, a periplasmic enzyme (Hooper, 1984). The production of AMO is regulated by the *amo* operon (Hooper, 1997). The prokaryotic mRNAs are polycistronic, meaning that there are multiple genes in a single transcript and there is a single promoter that initiates expression of the gene cluster. Most prokaryotes, AOB included, cluster a specific set of genes and transcribe those genes simultaneously. An operon is a group of closely linked genes that produces a single messenger RNA molecule in transcription and that consists of structural genes and regulating elements (Nelson, 2003). All AOBs studied thus far have contained up to three identical copies of the *amo* operon (Norton, 1996, Norton, 2000). Without the AOB, ammonia would be released in the sewage outfalls in full concentration due to the lack of conversion.

Most conventional secondary treatment processes fully nitrify and denitrify in order to remove the amount of incoming ammonia released into the environment. This approach uses considerable quantities of energy due to high dissolved oxygen (greater than 2.0mg/L) required to fully convert ammonia to nitrate supplied by blower equipment. Both the CWRP and OCWRP mitigate the need to increase energy costs by partially nitrifying the incoming flow to levels acceptable under Order No. 97-52 permit. This results in half of the amount of oxygen needed by keeping D.O. levels under 1.0mg/L with the same amount of recycled water being produced.

Controlling the conversion of ammonia is one of the main goals of the operators, but the slow growth rate of ammonia oxidizing bacteria has hampered the monitoring of these bacteria for routine process control. By the end of the 19<sup>th</sup> century, successful culture and isolation techniques were applied to discriminate between the sixteen recognized species of AOB (Purkhold, *et. al.* 2000). However, the slow growth rates of AOB and the tedious selective cultivation techniques made evaluation of their roles in the treatment process a difficult and non-conclusive process.

Standard Methods for the Analysis of Water and Wastewater cultivation technique requires 24-30 days for cultivation and analysis, with additional time needed to allow extended incubation time for more complete results (SM 2005). This method is similar to a most probable number test utilized for soil matrices (Alexander, 1982), where a quantitative result is obtained from different dilutions of inoculated *Nitrosolobus* or *Nitrosobacter* medium. Viable titer estimates and direct counting have also been employed by researchers in order to enumerate the AOB (Matulewich, 1975; McCaig, 1994). The flaws in these methodologies are the long incubation periods, the underestimation of AOB cell numbers, and medium selectivity bias (De Boer, 1991; Wagner, 1996). Understanding exactly which AOB are responsible for ammonia oxidation in the treatment plant is vital in order to better understand the appropriate process controls.

One key question is exactly what determines the makeup of AOB in wastewater treatment plants, from either a deterministic selection, meaning microbial communities arise from microorganisms best adapted to conditions in the treatment plant, or from colonization by organisms that arise from the surrounding environment by chance and are able to proliferate at the treatment plant (Rowan, 2003). This question is important to understand in order to deduce exactly which AOB species is performing the dominant oxidation in the treatment plant.

Traditionally, the obligate chemolithotrophic AOB have been grouped into the gram-negative family *Nitrobacteraceae*. There are five distinct genera which make up the AOB group: *Nitrosomonas*, *Nitrospirira*, *Nitrosovibrio*, *Nitrosolobus*, and *Nitrococcus* (Bergey's 2005). Molecular techniques have allowed the exploitation of the distinct phylogenetic differences of the AOB genera by the use of highly conserved 16S rRNA sequences (Woese, 1977). Molecular probes that target certain regions of bacterial genomes allow the clear identification of the target organism. By shifting the focus from



a culture-based evaluation to a molecularly based evaluation of the AOB, researchers are developing faster and more reliable AOB population data.

The AOB found in the environment are at low concentrations where there is minimal ammonia content. Nucleic acid sequence identification of these bacteria has shown that they are mainly of the *Nitrosospira* spp. (Hiorns, 1995; Kowalchuk, 2000). Engineered high ammonia environments (i.e. wastewater treatment plants), are found by in large to harbor the *Nitrosomonas* spp. (Juretsko, 1998; Wagner, 1995; Mobarry, 1996; and Ballinger, 1998). However, Hiorns et al. (1995) found *Nitrosospira* species, not *Nitrosomonas* species in an activated sludge plant.

In order to analyze the bacteria by molecular techniques, the first step requires the DNA to be extracted out of the sample. After evaluation of numerous ways to extract DNA, the sample matrix was determined to be most efficacious. For activated sludge samples, the method chosen in this study combined (i) mini-bead beating (which is most efficient at breaking up aggregate floc material), precipitation of impurities with ammonium acetate (Yu, 1999) and (iii) additional DNA extraction procedures with phenol and phenol-chloroform to remove contaminants that have coprecipitated with DNA (Tsai and Olson, 1991; Bourrain, 1999).

Once the DNA is extracted, molecular probes must be designed to target the sought population and must satisfy the following criteria: 1) a large portion of the gene should be recovered to allow complete identification of the target organism, 2) the probe should target all organisms in the genera, and 3) the probe should not amplify the target gene of members out of the target genera (Kowalchuk and Stephen, 2001). The first evidence of unique AOB based 16S rDNA sequence (McCaig, A.E., 1994) sought to amplify a large portion (1.1 kb) of the 16s rDNA portion, but this proved to provide false positives based on the third principle above. Refinement of the use of 16s rRNA sequence information for in situ analysis was developed by the elucidation of specific or semi specific primers of the 16s rDNA and direct or cloning-assisted sequence analysis of the obtained fragments of AOBs (Stephen, 1996; Speksnijder, 1998; Kowalchuk, 1997). The proliferation of molecular methods has refined the primers and probes developed by researchers to target certain genera of microorganisms in various matrices, including activated sludge.

In fact, some researchers have sought to amplify the *amoA* (Sinigalliano, 1995; Rothauwe, 1997; Mendum, 1999; Purkhold, 2000) and *amoB* (Calvo, 2004) genes from activated sludge samples, with the idea that by focusing on the structural *amoA* or *amoB* genes, rather than the 16S rRNA, false positive results would not be obtained. The problem with using the *amoA* molecular marker is that the *amoA* gene shares an evolutionary ancestry with the gene encoding the particulate methane monooxygenase (*pmoA*) (Holmes, 1995; Erwin, 2005). This is a problem due to the fact that the shared ancestry could result in co-amplification, thereby producing false positives and skewing the obtained cell numbers. Another problem with the use of the *amoA* or *amoB* genes is their varying copy numbers in different AOB populations, which could result in skewed actual cell numbers when data is normalized. The 16s rDNA portion of the AOB

contains only one copy number in the *Nitrosomonas* genera (Aakra, 1999) thereby eliminating skewed data. Also, the *amoB* gene is less effective due to the fact that it is too divergent from the core group of ammonia oxidizers, while the *amoA* gene is too small to be representative of the entire ammonia oxidizing population.

From this point the researcher may choose polymerase chain reaction (PCR), fluorescent in situ hybridization (FISH), or quantitative polymerase chain reaction (qPCR) to understand the ecology of the biomass or to enumerate the target population. Denaturing gradient gel electrophoresis (DGGE) of PCR-amplified 16S rDNA fragments is another current tool to understand the sequence diversity of the AOB populations (Speksnijder, 1998).

In 1991, Holland, et. al, developed an assay coupled with the PCR technique that detected specific products with the thermostable enzyme from the genome of the microorganism *Thermus aquaticus*, which laid the groundwork for the use of the PCR technique in practical real-world applications. PCR must be coupled with gel electrophoresis for confirmation of amplification of the target sequence, which is useful when the microbial makeup of the sample is previously unknown. Although the traditional PCR technique was not used in the quantification of the AOB cells, it was used to verify that the *Nitrosomonas* class resided in the activated sludge samples analyzed in this project (Hermansson, 2001).

The PCR method must be coupled with a MPN technique if quantitation is sought. A PCR MPN method for quantification of nitrifiers in soil (Both, 1990; Picard, 1992; Degrange, 1995) has been developed to also be applicable for activated sludge. The method requires a large amount of samples to be analyzed in order to produce statistically significant data. The MPN technique is labor intensive requiring nine DNA extractions per sample plus nine PCR reactions per DNA extract. The large amount of samples needed and multiple dilutions required for each sample do not allow for a routine method in process control.

Another quantitative PCR method that is more popular is the competitive PCR method. This method is based on the addition of an internal standard in the PCR reaction and the addition of a competitive template, which is amplified with the target template in the sample (STR, 1997; Dionisi, 2002; Bjerrum, 2002; Mumy, 2004; La Para, 2006). The addition of different amounts of the competitive template and the change in intensity of the product allows for the determination of the number of gene copies in the sample. While this method is easier to perform than the MPN method above, it still cannot be implemented into routine control in most wastewater treatment plants.

The aim of adequate treatment in activated sludge is to encourage aggregate growth (floc) in order for this material to settle out in the secondary clarifiers. The FISH technique now enables researchers to analyze the microbial ecology of floc particles *in situ* (Juretsko, 1998; Koops, 2001) in activated sludge as well as enter into a new stage of enumeration of the respective microorganisms with the aid of micro sensors (Schramm, 1999; Daims, 2001). The complex matrix of activated sludge has hampered previous

enumeration of *in situ* analysis, but with increased software features and confocal laser-scanning microscopy, this technique is starting to gain momentum. The FISH technique has shed much light on the community structure of the AOB. FISH techniques have revealed that the AOB reside solely on the floc and nitrification does not occur below 200  $\mu\text{m}$  of the floc particle's surface (Gieseke, 2001). This fact is important to note in order to deduce various process control parameters.

Quantitative PCR offers the ability to qualitatively deduce whether the target sequence was amplified and to quantitate the amount of cells present in the sample based on the positive standard addition. The qPCR methodology can produce results in as little as 2 hours, thus an operator who suspects an upset in the plant can obtain the results of this assay by the end of the working day in order to compare the results to baseline or healthy AOB population levels and make any changes as needed. The qPCR assay currently utilizes four different types of chemistries to obtain the quantifiable product. The chemistry system chosen for this project is the TaqMan® system supplied by Applied Biosystems in Foster City, CA.

After these results have produced the quantifiable amount of target DNA, the investigator will have to normalize the data (based on mass spectrometer results of extracted DNA) and then compare these numbers to chemical tests and process parameters in the aeration basin. This information will then allow for specific optimization of the partial nitrification process in the secondary treatment system in the aeration basin of the CWRP and the OCWRP. Enumeration of the AOB by the quantitative PCR technique is the method of choice for this analysis

Monitoring and controlling the treatment process by evaluating the key microorganisms involved in the nutrient conversion is an emerging scientific endeavor. For example, just last year LaPara and Ghosh (2006) at the University of Minnesota evaluated AOB community structure in the hopes of relating this structure to treatment efficiency at a full-scale municipal wastewater treatment facility. Their results suggested that there is a link between the quantity of the AOB population and effluent quality. The study used the nested PCR-DGGE method, which would not be feasible for routine process control. It was also concluded that further research would need to be accomplished to achieve better statistical correlation.

It is hypothesized that by elucidating exactly how many of the AOBs are contributing to the ammonia removal, one can predict and control the percent conversion of ammonia in the secondary treatment process at wastewater treatment plants, thereby avoiding permit violations and overall water quality. Quantifying the AOB population and comparing their numbers with the normal operational process controls will allow for the development of relationships that will help wastewater treatment plant (WWTP) operators control process fluctuations. It is hypothesized that the operator can minimize energy use by lowering D.O. levels to optimized levels while reducing nitrite accumulation, which leads to increased chlorine used downstream, all by controlling the AOB population.

## Materials and Methods

### a. Description of Sample Locations and Sewage Treatment Plants

The Chiquita Water Reclamation Plant (CWRP) treats approximately 4-6 million gallons per day and is augmented with flow from a flow equalization basin during times of low flow periods (12am-4am). The dimensions of the two aeration tanks at CWRP are as follows: 215 ft. (L) x 20 ft. (W) x 17 ft. (D), with a total volume of 1.094 million gallons. The CWRP process can be visualized in the following diagram:

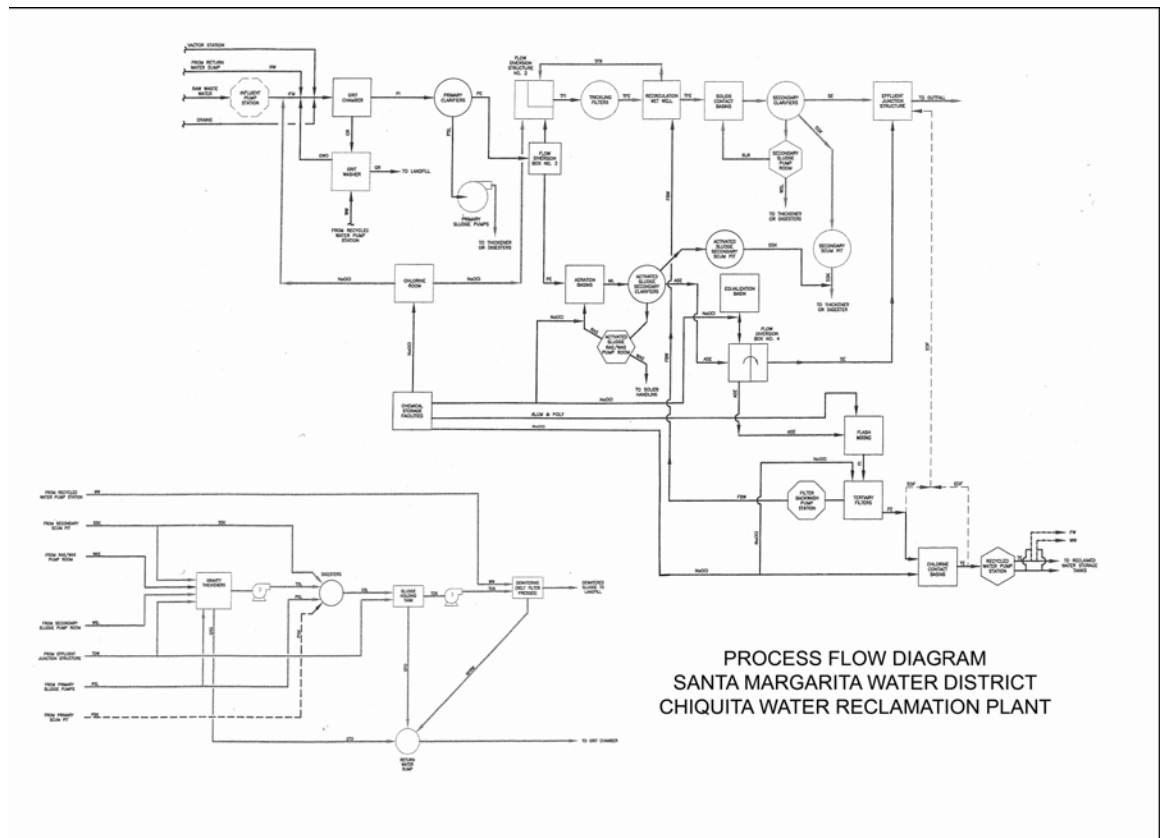

Figure 1: Process Flow Diagram for the Chiquita Water Reclamation Plant

The Oso Creek Water Reclamation Plant (OCWRP) treats approximately 2.5MGD. The dimensions of the three aeration tanks are as follows: 69 ft. (L) x 27 ft. (W) x 12 ft. (D), with a total volume of .5016 million gallons. The OCWRP process can be visualized in the following diagram:

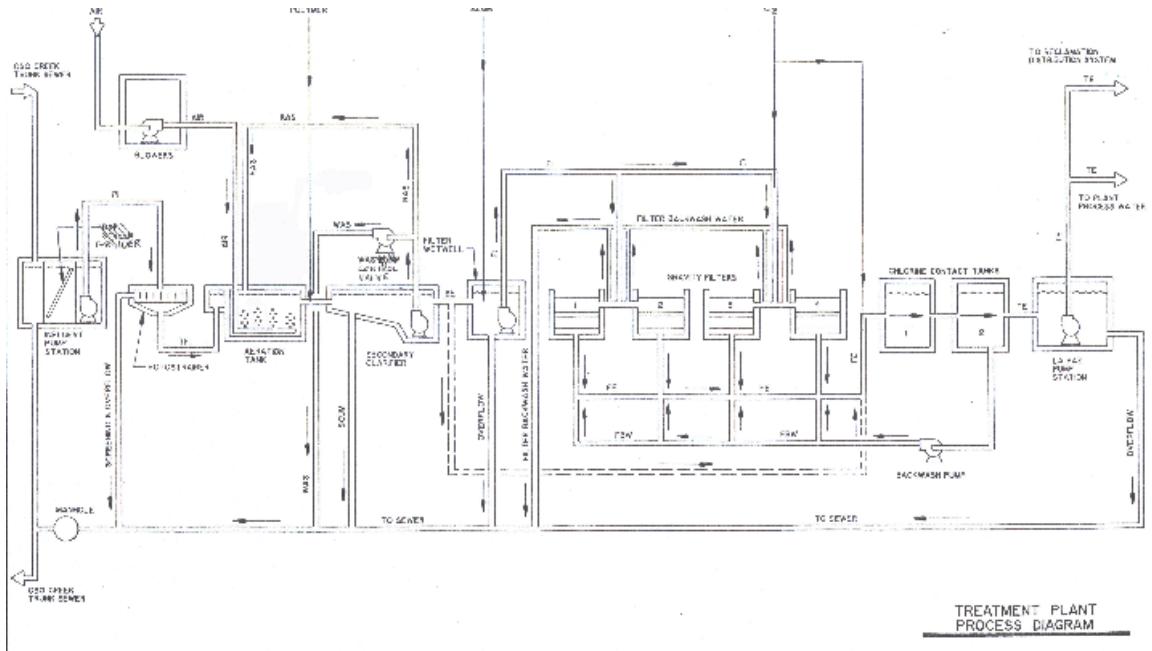

Figure 2: Process Flow Diagram for the Oso Creek Water Reclamation Plant

Sample Locations – MLSS samples were collected three times per week from the combined flows of the aeration tanks at the respective treatment plants in the months of February and March, 2007. A total of 22 samples were collected from each treatment plant. The majority of incoming flows from the treatment plants are domestic sewage (>90%).

## b. Physical and Chemical Tests

### i. Physical Tests:

Total Suspended solids (TSS) were analyzed according to Standard Methods 2540B on the activated sludge sample in duplicate. TSS was also run on influent and effluent flows associated with the aeration basin.

### ii. Nitrogen Series of Tests:

Since this investigation is to develop an approach that complement existing operations procedures a HACH digital colorimeter (Model # DR 890) was used to measure influent and effluent ammonia-nitrogen (mg/L) and nitrite-nitrogen (mg/L). The method chosen for ammonia-nitrogen analysis was HACH method 8155. The method chosen for the analysis of nitrite-nitrogen was the HACH method 8507.

### iii. Other Chemical Tests:

The pH and temperature were recorded as soon as the combined activated sludge sample was delivered into the laboratory. The samples that were

taken on the weekend were stored in the lab refrigerator (<4 degrees Celsius). Influent and effluent data on total biochemical oxygen demand removal and carbonaceous biochemical oxygen demand (Standard Methods 5210A) and alkalinity removal (Standard Methods 2320) will be used in the analysis portion. Standards will be used for quality control and accuracy.

c. DNA extraction

Each sample location (twenty-two samples in total experiment) had triplicate extraction performed.

**Step 1:** Blended mixed liquor sample for one minute in a blender to homogenize the sample.

**Step 2:** Centrifuged 1.0 mL mixed liquor at 16,000 x g for 5 minutes at 4°C and decant.

**Step 3:** To the pellet, added 2.0g of zirconia/silica beads (1mm in diameter), 1mL of extraction buffer.

**Step 4:** Bead beaten for 5.0 min at 5000 rpm and centrifuged at 16000 x g for 3 minutes at 4°C.

**Step 5:** Collected the supernatant in a fresh tube. To the pellet, add another 1.0mL of extraction buffer and repeated the previous step.

**Step 6:** Pooled the two supernatants, added ammonium acetate to a final concentration of 2M from a 10M stock solution, and mixed well.

**Step 7:** Stored mixture on ice for 5 min, centrifuged at 16000 x g for 10 minutes at 4°C, and collected the supernatant in a fresh microcentrifuge tube.

**Step 8:** Added 500uL phenol/chloroform, vortexed to mix well, and centrifuged at 13,000rpm for 5 minutes.

**Step 9:** The top layer was then collected in a new tube and 500uL of chloroform was added, then vortexed to mix well and centrifuged at 13,000rpm for 5 minutes, and the supernatant was collected in a fresh tube.

**Step 10:** The nucleic acids were precipitated from the supernatant with 1 volume of isopropanol and left either overnight at -20°C or at least one hour. Then the sample was centrifuged at 16000 x g for 15 minutes at 4°C. The pellet was then rinsed with 70% ethanol, centrifuged for 5 minutes and the supernatant removed.

**Step 11:** The microcentrifuge tubes were then dried upside down for an hour.

**Step 12:** The DNA was then resuspended in 100µL of HPLC water.

**Step 13:** The samples were then stored at less than 20°C until the sample could be analyzed by qPCR.

Refinement of Procedure and Sample Holding Time Experiments:

- i. In the second week of DNA extraction an experiment was performed so that time might be saved in the extraction method. In one out of three extractions from each mixed liquor sample no second bead beating was performed to see if there was a large percent difference in

the no second bead beating extraction as compared to the mean of the other two duplicate extractions from the same sample.

- ii. Sample holding time was also tested to determine if the DNA extraction would benefit from freezing the pellet after step 1 (Limpiyakorn, 2005), if the sample could not be analyzed immediately.

d. Purity of DNA extracted

In order to assess the purity of DNA extracted and to be able to normalize data at the end of the experiment, the extracted DNA was measured as a ratio of 260nm/280nm on a mass spectrophotometer in the Olson Laboratory. The 260nm wavelengths measure the purity of the nucleic acid, while the 280nm wavelength measures the proteins present in the sample. Therefore, when the 280nm wavelength increases due to the amounts of proteins present in the sample, this indicates a less pure sample. The closer the ratio is to 2.0, the higher the purity of the sample extraction. Activated sludge is a complex matrix that will not normally reach the 2.0 ratio, especially with the type of extraction performed in this experiment. The ratio could be improved with DNA purification kits, but the cost of these kits are expensive compared to the DNA extraction performed here.

e. Primer and Probe Selection

The literature review focused on papers that were analyzing AOB in municipal wastewater treatment plants. Primer and probe sequences were blasted using the NCBI website's Blast N program. All searches matched the total bacteria and AOB respectively. Applied Biosystems synthesized the primers and probes used in this project.

Table 1: Primers and Probes chosen for this project

Bacterial Group	Primer or Probe	Nucleotide Sequence (5'-3')	Reference
	<b>Primers</b>		
Total	1055f	ATGGCTGTCGTCAGCT	Harms, 2003
Total	1392r	ACGGGCGGTGTGTAC	Harms, 2003
AOB	CTO 189A/B f	GGAGRAAAGCAGGGGATCG	Kowalchuck, 1997
AOB	CTO 189C f	GGAGGAAAGTAGGGGATCG	Kowalchuck, 1997
AOB	RT1r	CGTCCTCTCAGACCARCTACTG	Hermansson, 2001
	<b>Probes</b>		
Total	16Staq1115 (5'-FAM	CAACGAGCGCAACCC	Harms, 2003

	and 3'BHQ)		
AOB	TMP1 (5'- FAM and 3'BHQ)	CAACTAGCTAATCAGRCATCRGCCGCTC	Hermansson, 2001

f. qPCR Assay

**Total Bacteria** – Bacterial 16S rDNA was amplified using primers 1055f (Harms, 2003) and 1392r (Harms, 2003) and probe 16Sta1115 (Harms, 2003). The PCR master mix was a total of 25 uL volume contained 1X PCR Buffer (10X), 3mM MgCl<sub>2</sub>, 0.2uMdTPs, 0.2uM forward and reverse primers, 0.15uM probe, 1U Taq polymerase, 0.02-4.0ng sample DNA or serial dilutions of the M20A plasmid carrying a 16S rDNA gene of total bacteria. The optimization reaction for total bacteria was 3 minutes at 50°C, 10 minutes at 95°C, 45 cycles of 30s at 95°C, 1 minute at 50°C, and 20 seconds at 72°C. The instrument used to perform the qPCR reaction was the Corbett Rotorgene 3000. The detection limit for total bacteria was  $2.8 \times 10^{-15}$ - $2.8 \times 10^{-9}$ .

**AOB** – AOB 16s rDNA was amplified using a two to one ratio of forward primers CTO 189 A/B f (Kowalchuck, 1997) to CTO 189C f (Kowalchuck, 1997) and reverse primer RT1r (Hermansson, 2001). The PCR master mix was a total of 25 uL volume contained 1X PCR Buffer (10X), 3mM MgCl<sub>2</sub>, 0.2uMdTPs, 0.2uM forward and reverse primers, 0.15uM probe, 1U Taq polymerase, 0.02-4.0ng sample DNA or serial dilutions of the bacterial DNA from *Nitrosomonas Europea* (ATCC Accession Number 19718d). The optimization reaction for AOB was 2 minutes at 50°C, 10 minutes at 95°C, 40 cycles of 30s at 95°C, 1 minute at 60°C. The instrument used to perform the qPCR reaction was the Corbett Rotorgene 3000. The detection limit for AOB was  $310 \times 10^{-15}$ - $3.1 \times 10^{-9}$ .

g. Ammonia-Oxidizing activity per cell-hour

$$\text{Activity} = \frac{(NH_{3IN}^+ - 0.2 * NH_{3Up}^+ - NH_{3Out}^+) \times Q}{AOB}$$

Equation 5

- NH<sub>3</sub><sup>+</sup><sub>IN</sub> = Average Ammonia concentration (mg/L as nitrogen) of the influent to the aeration basin
- NH<sub>3</sub><sup>+</sup><sub>OUT</sub> = Average Ammonia concentration (mg/L as nitrogen) of the effluent out of the aeration basin
- NH<sub>3</sub><sup>+</sup><sub>UP</sub> = Assimilation of ammonia in the bacterial cell (assuming 20% of influent Ammonia-Nitrogen) – (mg/L)



## h. Gel Electrophoresis and Visualization

Gels were prepared by first calculating the quantity of agarose needed as a function of the size of the mold. The quantity of agarose needed was: 80mL (size of mold) \*2% (agarose percentage) = 1.2g of agarose in 80mL of TAE (Tris-Acetate-EDTA). This mixture was then heated in a microwave in 30s intervals until the agarose was completely dissolved. The 3uL of ethidium bromide was added to the mixture, and this mixture was then poured into the electrophoresis mold, with combs in place to allow for sample injection. After the mold had set, the combs were removed and TAE was poured into the gel box to just over 1cm of the gel. 100bp ladders were added to the first and last injection wells in order for the product to have a comparative key to be judged against. Each PCR product was added to 3uL of dye respectively and then injected into the wells. The leads were then attached, the voltage was turned to 100v and proceeded to run for approximately 2.5 hours, or until the products traveled ½ way to the second comb. The gel was then visualized with a transilluminating filter in the Alpha Imager 3300 program.

## i. Operating parameters – formulas used to assess process stability

- i. Solids Retention Time (SRT-days) – evaluates the length of time solids are retained in the aeration basin system alone, before the solids are removed from the system.

Equation 6:

$$\text{SRT} = \frac{\text{Volume of Aeration Tank (MG)} * \text{Aeration Tank MLSS (mg/L)}}{\text{Wasting Rate(MGD)} * \text{RAS MLSS(mg/L)} * 8.34 + \text{Eff. MLSS(mg/L)} * \text{Eff. Flow (mg/L)} * 8.34}$$

- ii. Food to Mass Ratio (f/m) – evaluates the incoming BOD as compared to the microbial population (measured as a function of MLVSS)

Equation 7:

$$f/m = \frac{\text{Avg. Flow (MGD)} * \text{Total Influent BOD (mg/L)} * 8.34}{\text{Volume of Aeration Tank (MG)} * 8.34 * \text{Avg. Aeration Tank MLVSS (mg/L)}}$$

- iii. Minimum SRT (SRT – Days) – evaluates the minimum theoretical amount of time needed to prevent washout of *Nitrosomonas* bacteria. Since the *Nitrosomonas* class was found at both plants, this operating parameter can be used to control partial nitrification in the respective treatment plant.

Equation 8:

$mSRT \text{ (Days)} = 3.05 * 1.27^{(T \text{ (}^\circ\text{C)} - 20)}$ ; Where T=the temperature of the aeration basin MLSS

- iv. Organic Loading – This measures the amount of organic material in the entering into the secondary treatment process.

Equation 9:

$$\text{Organic Loading} = \frac{\text{Avg. Flow (Influent, MGD)} * \text{Total Influent BOD (mg/L)}}{\text{Volume of aeration tanks (MG)} * 1000}$$

- v. Detention Time – The theoretical time that it takes one microorganism to traverse the aeration tank.

Equation 10:

$$\text{Detention Time} = \frac{\text{Volume of Aeration Tank (MG)} * 24 \text{ (hours)}}{\text{Avg. Flow (MGD)} * \text{RAS, Flow (MGD)}}$$

j. Data Analysis

- i. Parametric statistics were employed due to the fact that the author felt that the variables were distributed in a Gaussian manner. Data was compiled and sorted in ascending order and a matrix was created that evaluated the correlation between the independent variables (MLSS, D.O., etc.) vs. the dependent variables (cell number of total bacteria or AOB/L). When correlation coefficients were greater than 0.90, further analysis as to the relationships that variables had on each other were examined. Linear regression analysis was employed to assess the true relationships between variables in graphical format.
- ii. Cell numbers per liter of MLSS sample were calculated by normalizing the data to account for the amount of DNA extracted from each sample. The normalization of data was accomplished in a two-step procedure, with a third to account for greater than 1 copy number.

Equation 11: Copies per reaction back to rehydration volume

$$\text{Copies/Reaction} = \text{Copies/5uL Sample inserted into qPCR reaction} * \left[ \frac{100 \text{ uL HPLC/5uL sample in qPCR reaction}}{1 \text{ mL sample originally extracted}} \right]$$

Equation 12: Cells/L

$\text{ng DNA/uL (from Mass Spec.)} \times [100\text{uL (total Mass Spec. Volume)} / 1\text{mL sample extract}]$

Equation 13: Adjusting for copy numbers

$[\text{Cells/L}] / \text{Copy number of 16S rRNA genes}$

## Results

- a. **Sample location** - To deduce whether MLSS was significantly different from the separate aeration tanks a two-tailed student's t-test was performed and it was found that there was no significant difference in the sample location's MLSS. The statistical hypothesis was that the means of the measurement value (MLSS) are equal for the separate tanks and the combined tank. The fact that the student's t-tests does not produce significant results under the desired  $\alpha > 0.05$ , the null hypothesis can be accepted as proof that the sample locations do not produce statistically significant results. (See Table 2)

Table 2: Sample Location Justification – Student's t-test

Oso Treatment Plant				Chiquita Treatment Plant			
Combined Flow vs. Separate Tanks				Combined Flow vs. Separate Tanks			
Date	Separate Tank Avg. MLSS (mg/L)	Combined Tank Avg. MLSS (mg/L)	T Test (P value)	Date	Combined Tank Avg. MLSS (mg/L)	Separate Tank Avg. MLSS (mg/L)	T Test (P value)
2/9/2007	1894.00	2378.00	0.12	2/14/2007	2263.00	2587.00	0.41
2/12/2007	2520.00	2191.00		2/21/2007	2465.00	2591.00	
2/20/2007	2018.00	2676.00		2/28/2007	2377.00	2514.00	
2/26/2007	1728.00	2992.00		3/7/2007	2696.00	2649.00	
3/5/2007	2308.00	2332.00		3/14/2007	2672.00	2696.00	
3/12/2007	2282.00	2245.00		3/21/2007	2642.00	2573.00	
3/19/2007	2426.67	2439.00		3/28/2007	2241.00	2277.00	
3/26/2007	2407.33	2188.00					

- b. Analytical and Operating Parameters at CWRP & OCWRP.

The highlighted portions represent values taken from the SCADA programming platform or from the wastewater treatment plant operator calculations. The non-highlighted values were obtained from the work of laboratory staff at the CWRP.

Table 3 Average Operating and Analytical Parameters:

Analytical Parameter	Chiquita Water Reclamation Plant	Oso Creek Water Reclamation Plant
MLSS (mg/L)	2556.86	2370.50
MLVSS (mg/L)	2034.32	2045.14
Flow (MGD)	4.42	1.94
RAS Flow (MGD)	1.79	1.07
Dissolved Oxygen (mg/L)	0.70	3.69
Temperature (Degrees Celsius)	21.63	18.30
pH	7.20	7.33
Influent MLSS (mg/L)	91.67	179.79
Influent MLVSS (mg/L)	84.63	168.48
Effluent MLSS (mg/L)	5.70	17.97
Effluent MLVSS (mg/L)	5.23	16.64
Influent Ammonia (mg/L)	39.59	32.17
Effluent Ammonia (mg/L)	24.50	18.30
%Ammonia Removed	37.25	43.47
Effluent Nitrite (mg/L)	0.62	0.93
Effluent Nitrate (mg/L)	6.48	0.75
Influent Alkalinity (mg/L)	274.95	245.19
Effluent Alkalinity (mg/L)	199.27	193.68
% Alkalinity Removed	27.44	21.29
Influent Total BOD (mg/L)	171.77	186.08
Effluent Total BOD (mg/L)	19.85	20.19
% Total BOD removed	88.20	88.30
% NBOD removed	71.40	48.10
SRT (Days)	3.82	3.21
f/m	0.34	0.33
Minimum SRT needed (Days)	4.82	4.73

c. DNA extraction

- i. The second week's analysis showed that 83.3% of the time the purity, as measured by the ratio (260nm/280nm), of the samples that were subjected to a second bead beating increased. It also showed that 67% of the time bead beating the sample a second time resulted in a greater DNA yield. This can be seen in Table 4 below, as well as in graph 1 below.

Table 4: Comparison of DNA Purity Ratio and the Percent DNA Yield

Sample Date	Sample Alias	% Difference of Ratios	% Difference of Yield
2/18/2007	C3	6.215	-33.074
2/18/2007	O3	-2.039	79.170
2/20/2007	C3	4.427	25.766
2/20/2007	O3	7.384	32.588
2/21/2007	C3	1.316	-76.008
2/21/2007	O3	15.611	53.205

Figure 3: Representation of the Percent Difference in No Second Bead Beating

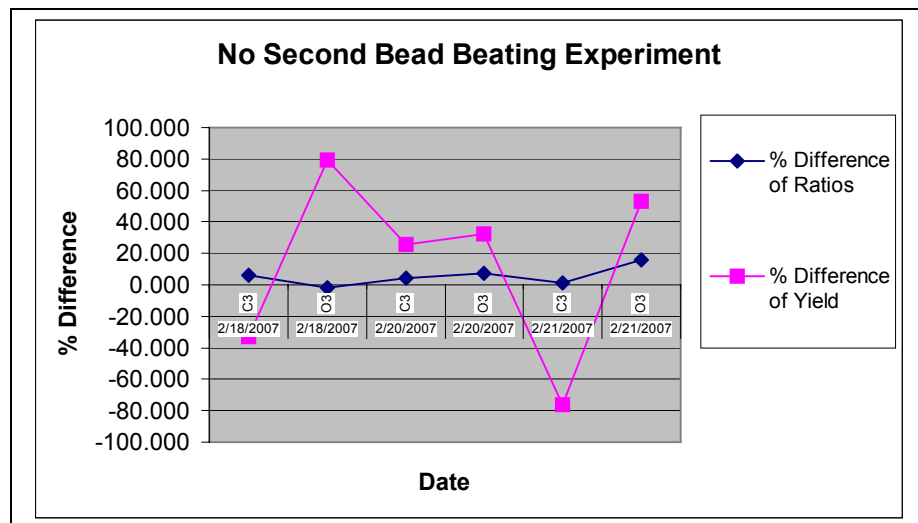

- ii. The Limpiyakorn evaluation of twelve sewage treatment plants in Tokyo stated that after the supernatant was removed, the pellet was kept at  $-20^{\circ}\text{C}$  until analysis. This method was applied in weeks 3 & 4 and indicates that there is a better DNA extraction when the Limpiyakorn method is used if the sample cannot be analyzed right away. The method increased the DNA yield by 36.08% if the one-week where the method did not increase the DNA yield was included (3/1/07 – negative value) and 53.40% when this data point was excluded.

Table 5: Analysis of Limpiyakorn Method

Date	Treatment Plant	Limpiyakorn Method	No Limpiyakorn. Method	% Difference
2/25/2007	CWRP	88.28	11.44	87.05
	OWRP	22.99	9.10	60.43
3/1/2007	CWRP	211.58	36.69	82.66
	OCWRP	43.18	64.99	-50.52
3/4/2007	OCWRP	103.34	94.63	8.43
	OCWRP	64.59	46.22	28.44

d. Ammonia-oxidation per cell per hour

The CWRP AOB oxidation per cell per hour averaged 39.76 fmol, with a range of 0.02-286.28 fmol. The OCWRP AOB oxidation per cell per hour averaged 15.60 fmol with a range of 0.02-131.95 fmol.

e. Gel picture and justification of the *Nitrosomonas Europea* standard used in qPCR.

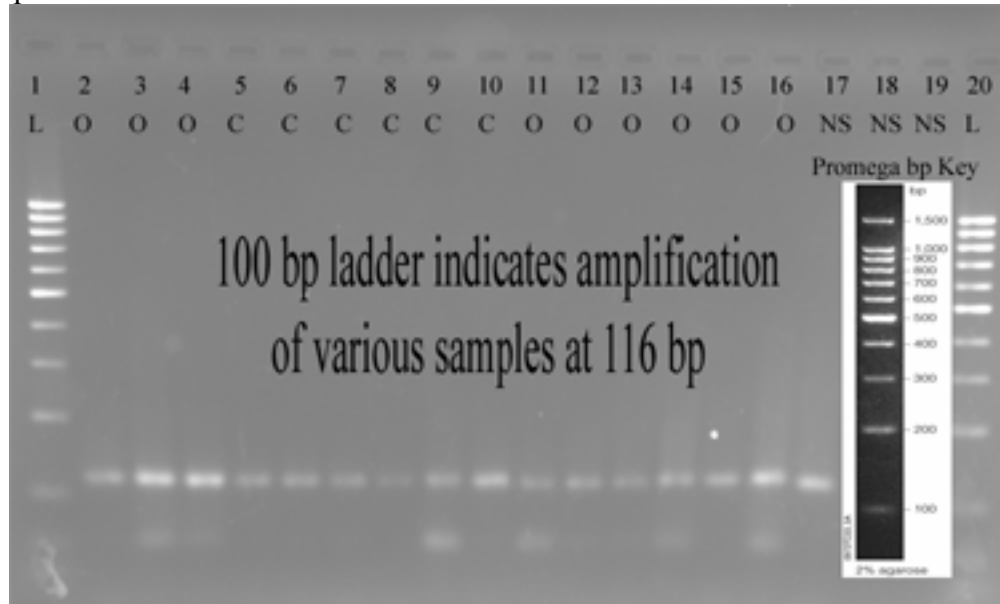

Figure 4: Picture of Gel Using *Nitrosomonas Europea* primers and probes

**Key:**

L=100bp ladder	C=Samples from CWRP
NS=No Sample Injected	O=Samples from OCWRP

Promega bp key obtained from the Promega website.

f. Total Bacteria and AOB Numbers & % AOB at CWRP and OCWRP

i. The cells/L of total bacteria at CWRP were  $5.95 \times 10^9$ - $3.64 \times 10^{14}$ . The cells/L of AOB at CWRP were  $2.02 \times 10^7$ - $5.03 \times 10^9$ . The average % of AOB compared to total bacteria was 3.01%. This value fluctuated between 0.000325-32.03%. This relationship over time can be seen in Graphs below.

Figure 5: Total Bacteria vs. Total AOB at CWRP with confidence intervals

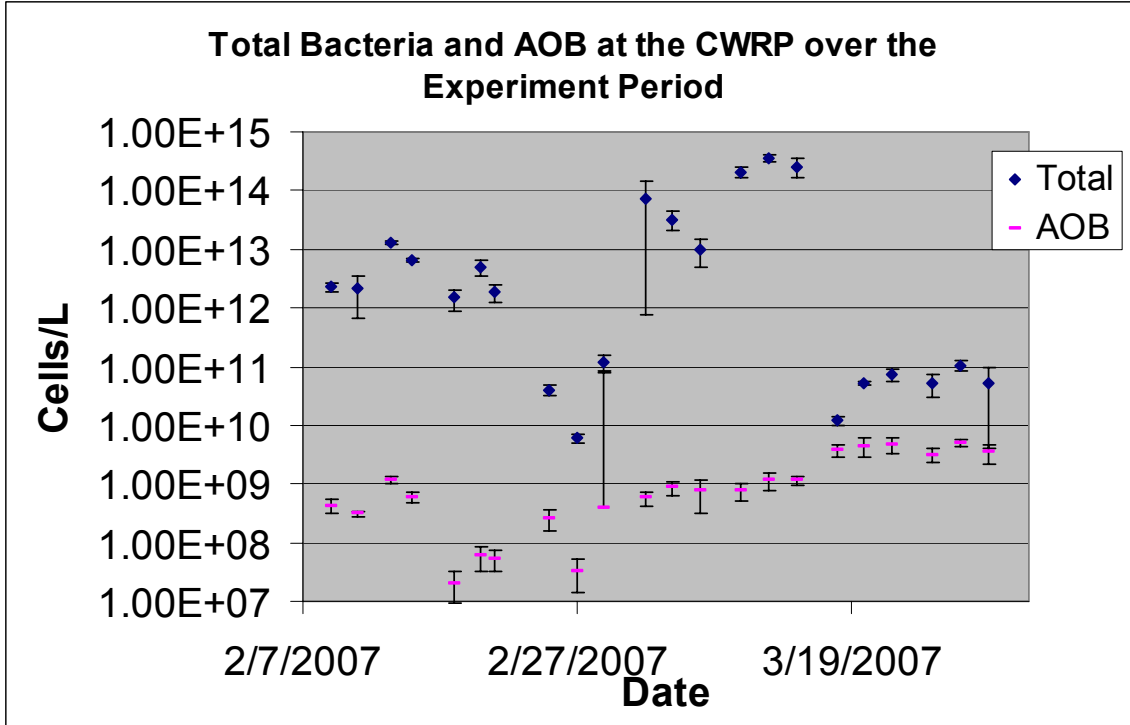
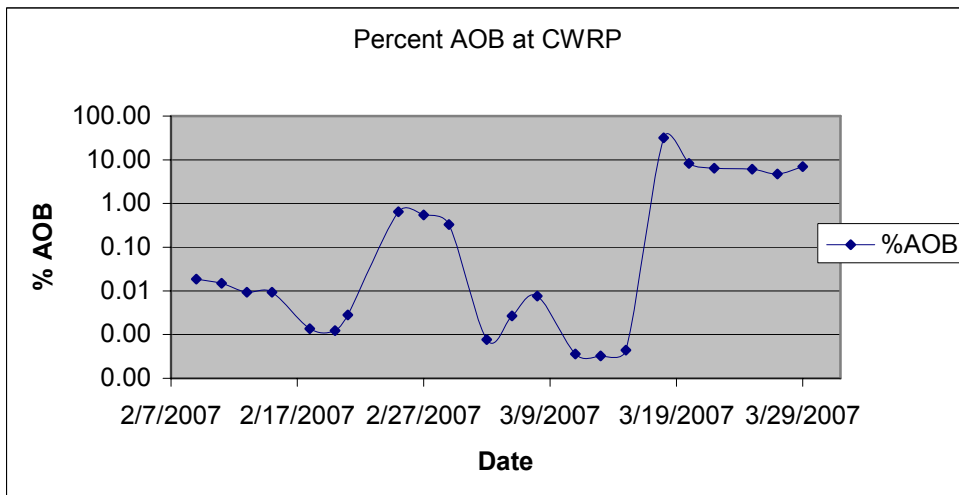

Figure 6: Percent AOB at CWRP over Experiment Period





ii. The cells/L of total bacteria at OCWRP were  $1.32 \times 10^9$ - $4.13 \times 10^{14}$ . The cells/L of AOB at OCWRP were  $5.44 \times 10^6$ - $9.06 \times 10^9$ . The average % of AOB compared to total bacteria was 1.598%. This value fluctuated between 0.000358-8.518%. This relationship over time can be seen in Graph 3 below.

Figure 7: Total Bacteria vs. Total AOB at OCWRP

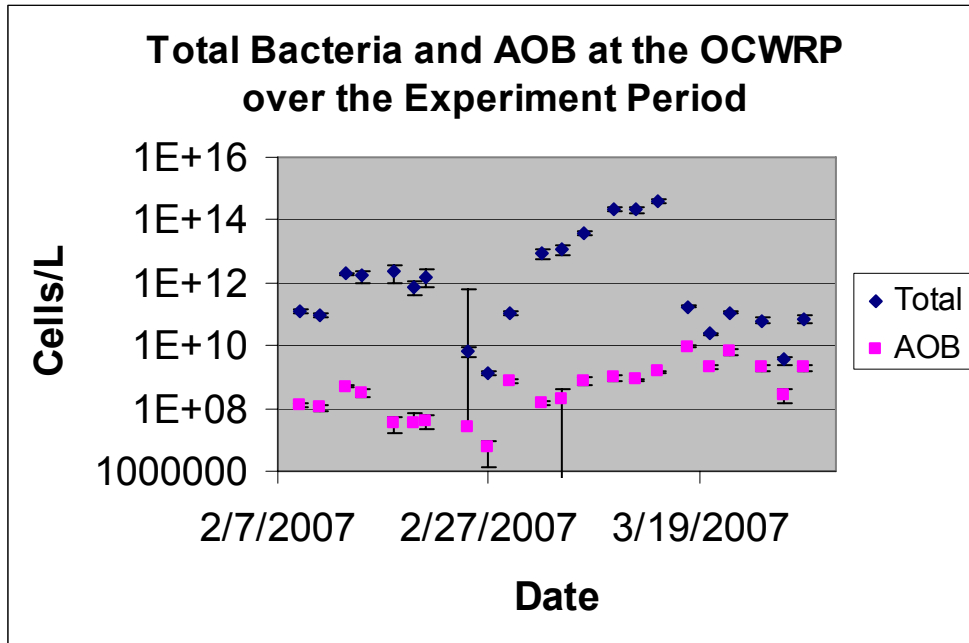
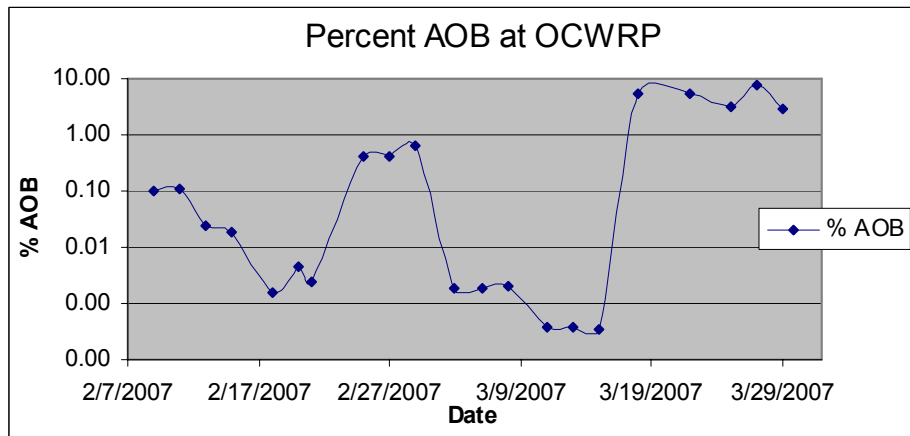

Figure 8: Percent AOB at OCWRP over Experiment Period



g. Correlation Results

The following table shows the correlation coefficients obtained for the analysis of independent vs. dependent variables at the CWRP and OCWRP. All data was ranked from low to high before the correlations were analyzed.

Table 6: Statistical Correlation between Independent and Dependent Variables

<b>CWRP</b>	Dependent Variables		<b>OCWRP</b>	Dependent Variables	
Independent Variables	Total Bacteria	AOB	Independent Variables	Total Bacteria	AOB
MLSS	0.52	0.95	MLSS	0.84	0.89
MLVSS	0.68	0.88	MLVSS	0.79	0.84
DO	0.73	0.95	DO	0.77	0.85
RAS	0.81	0.92	RAS	0.05	0.10
FLOW	0.62	0.84	FLOW	0.87	0.93
WAS	0.46	0.73	WAS	0.03	0.20
Total Influent BOD	0.75	0.93	Total Influent BOD	0.53	0.63
Total Effluent BOD	0.92	0.92	Total Effluent BOD	0.71	0.80
Amm. Ox/Cell/Hr	0.99	0.84	Amm. Ox/Cell/Hr	0.94	0.98
%Alk. Removal	0.70	0.89	%Alk. Removal	0.81	0.86
ALK DROP	0.14	0.30	ALK DROP	0.80	0.84
AMM DROP	0.69	0.92	AMM DROP	0.67	0.78
% Amm. Rem.	0.68	0.91	% Amm. Rem.	0.78	0.86
NO2	0.68	0.87	NO2	0.91	0.98
NO3	0.73	0.92	NO3	0.79	0.83
f/m	0.81	0.88	f/m	0.67	0.75
DT	0.83	0.92	DT	0.88	0.93
Organic Loading	0.74	0.92	Organic Loading	0.65	0.75
Sec. Effluent Turbidity	0.80	0.95	Sec. Effluent Turbidity	0.91	0.93

CWRP Graphs of Correlated Parameters

Figure 9: MLSS as it relates to AOB Cells/L at CWRP

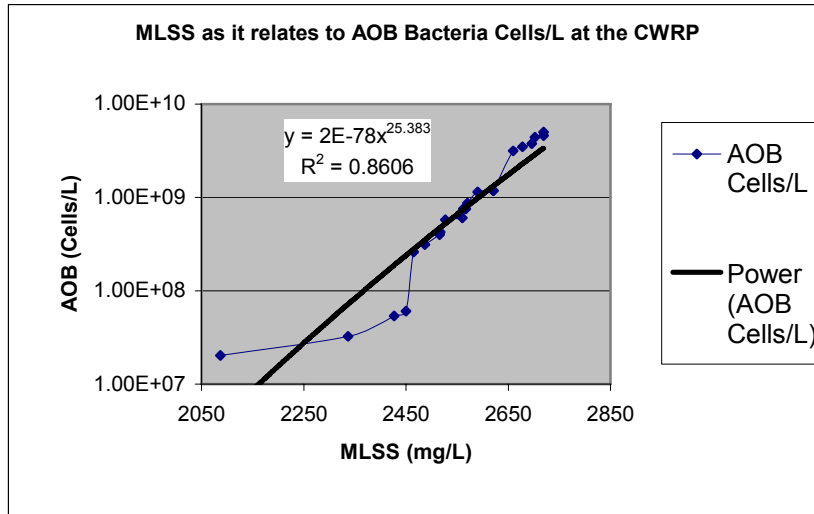

Figure 10: Total Bacteria and Total AOB vs. D.O. Requirement at CWRP

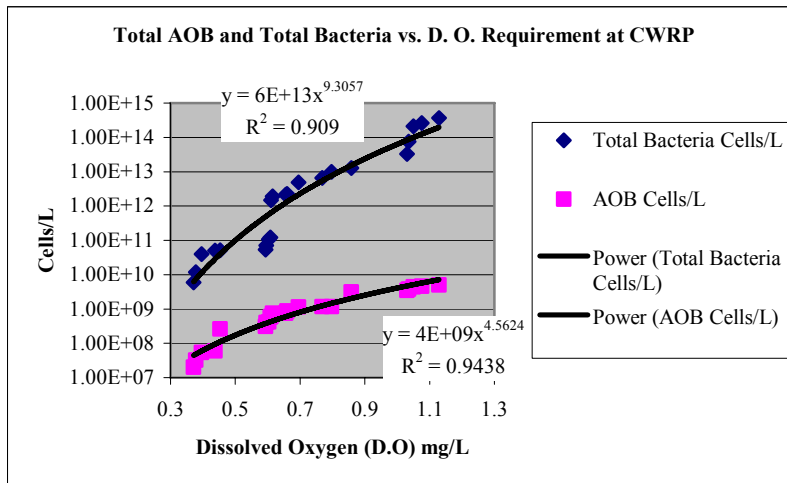

Figure 11: RAS as it relates to AOB Cell/L at CWRP

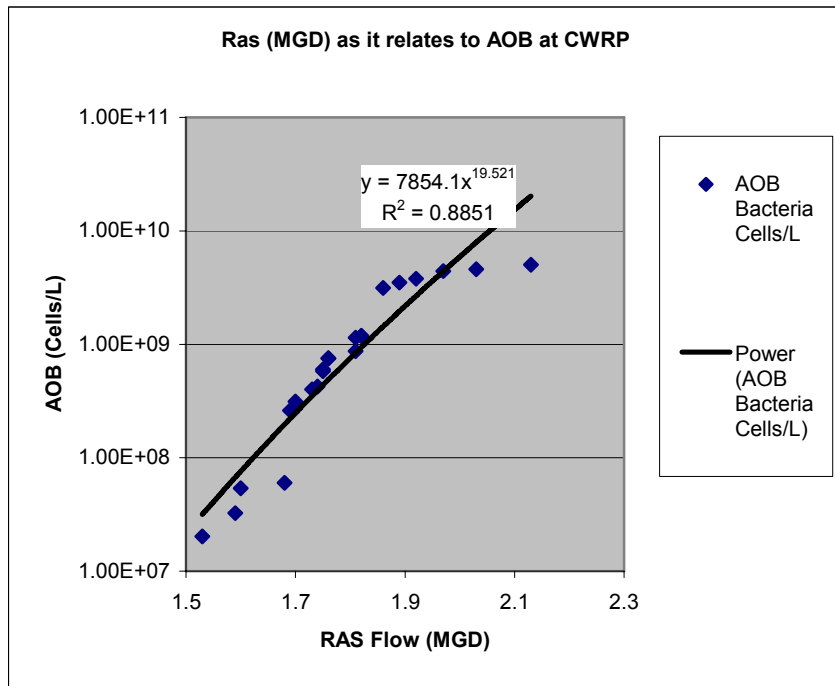

Figure 12: Total Influent BOD as it Relates to AOB Cells/L at CWRP

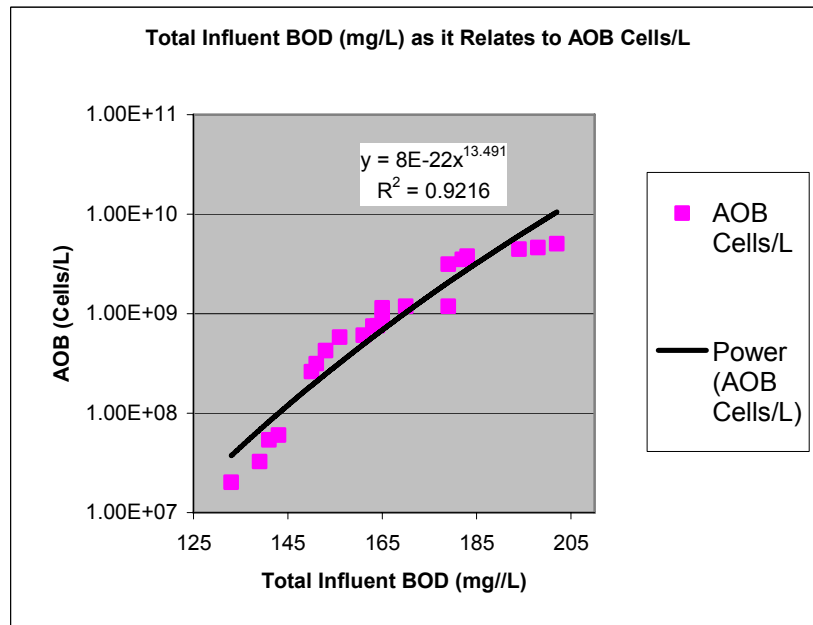

Figure 13: Total Effluent BOD as it Relates to AOB Cells/L at CWRP

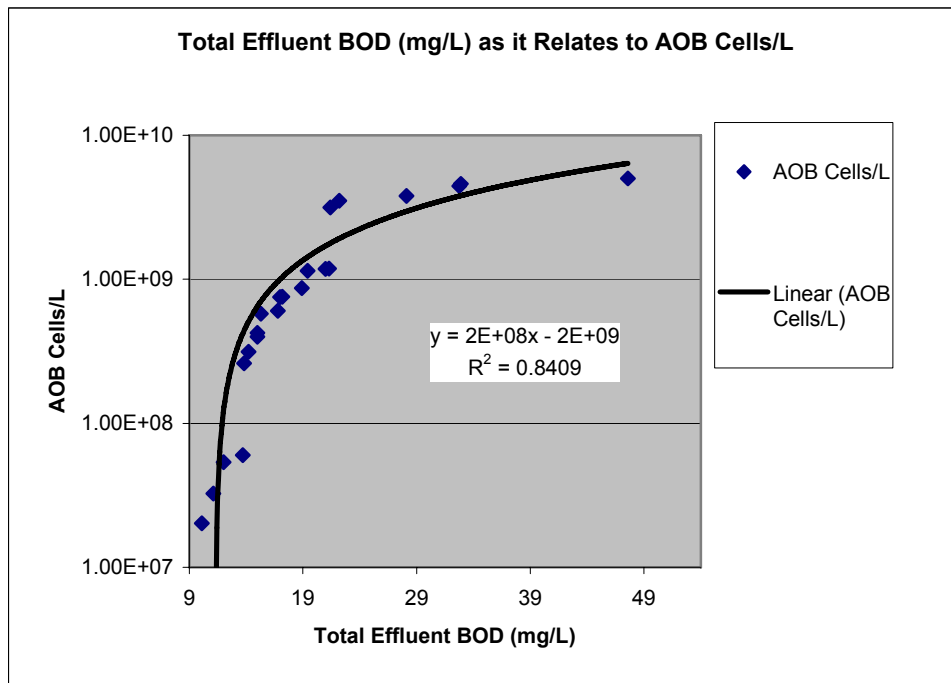

Figure 14: Ammonia Removal as it Relates to AOB Cells/L at CWRP

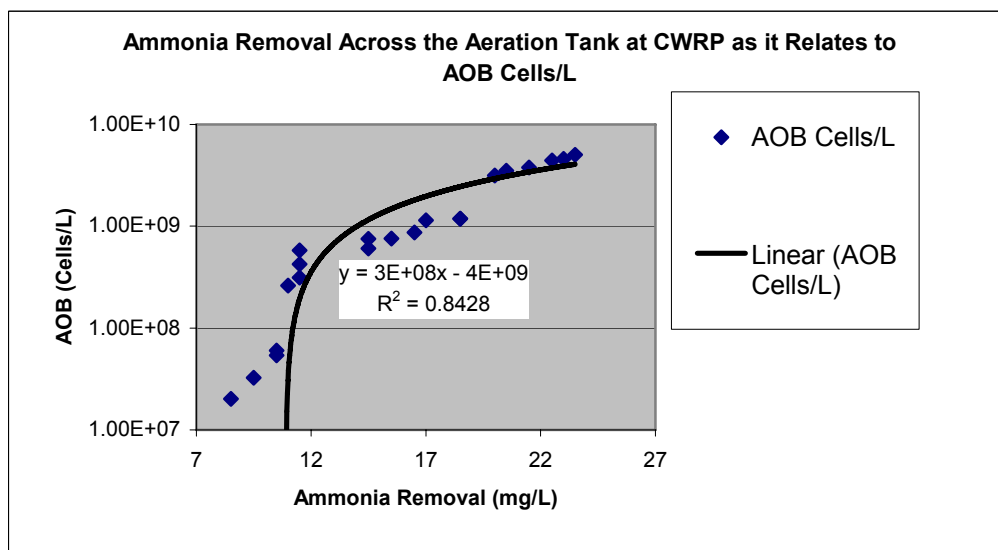

Figure 15: The relationship between the percent of ammonia removed and AOB concentration at CWRP

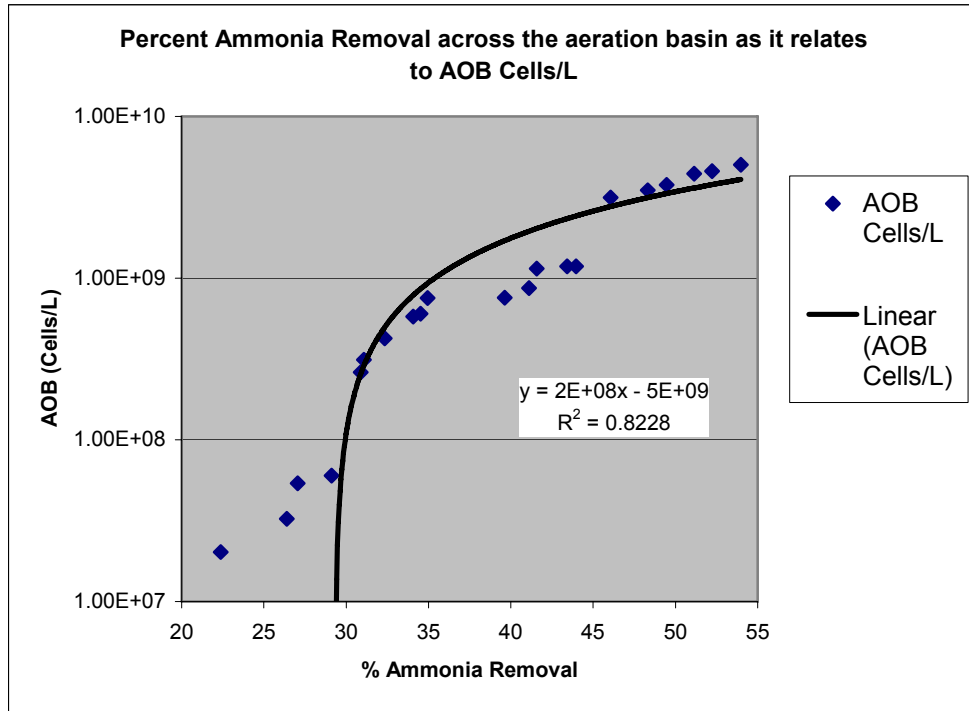

Figure 16: Effluent Nitrate Concentration as it Relates to AOB Cells/L at CWRP

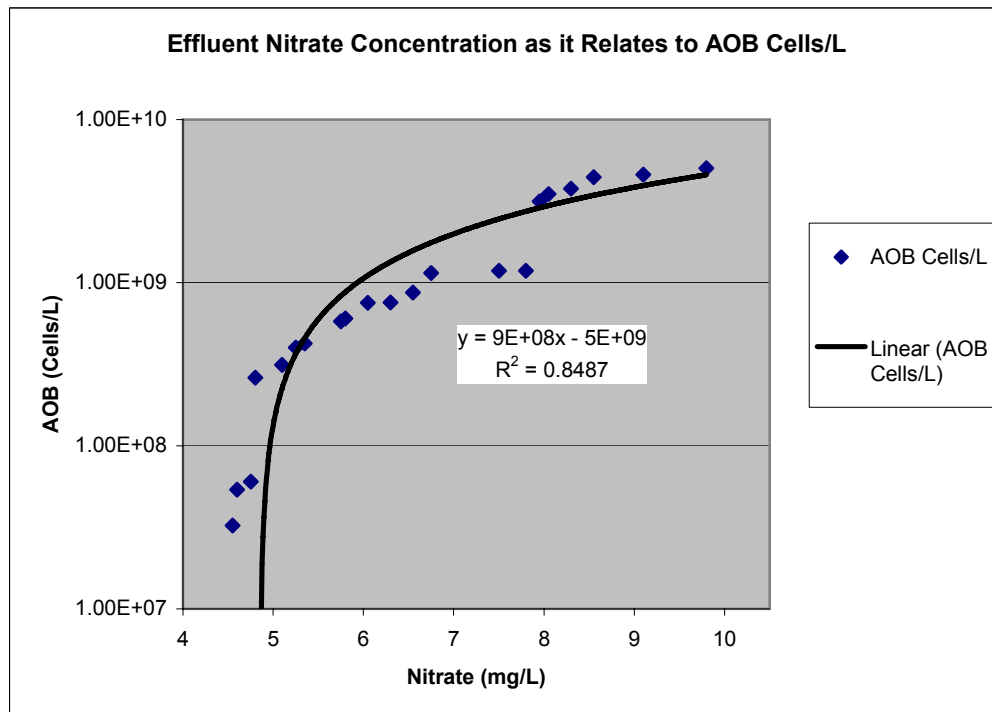

Figure 17: Detention Time as a Function of AOB Cells/L at CWRP

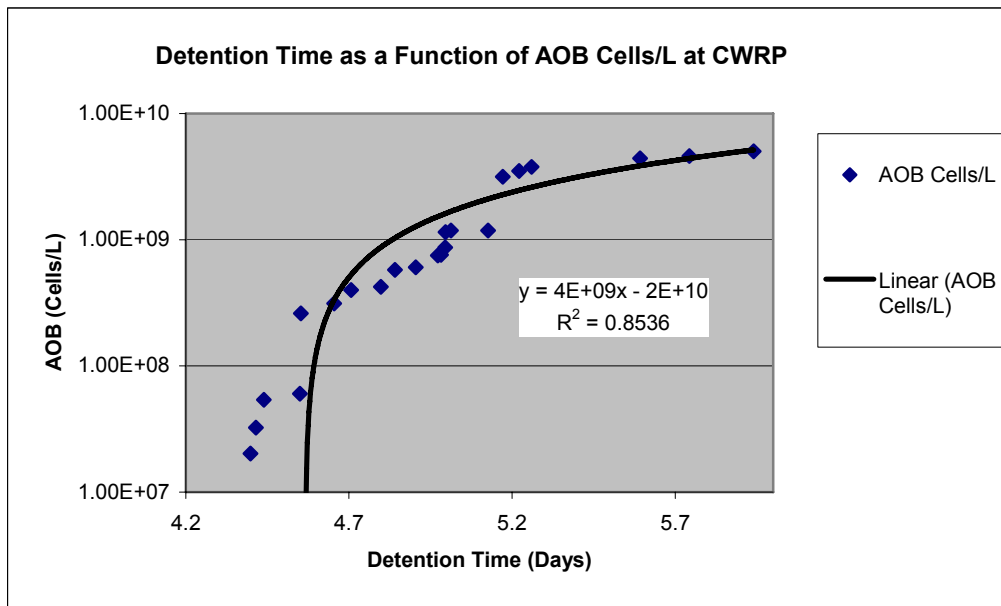

Figure 18: Organic Loading as it Relates to AOB Cells/L at CWRP

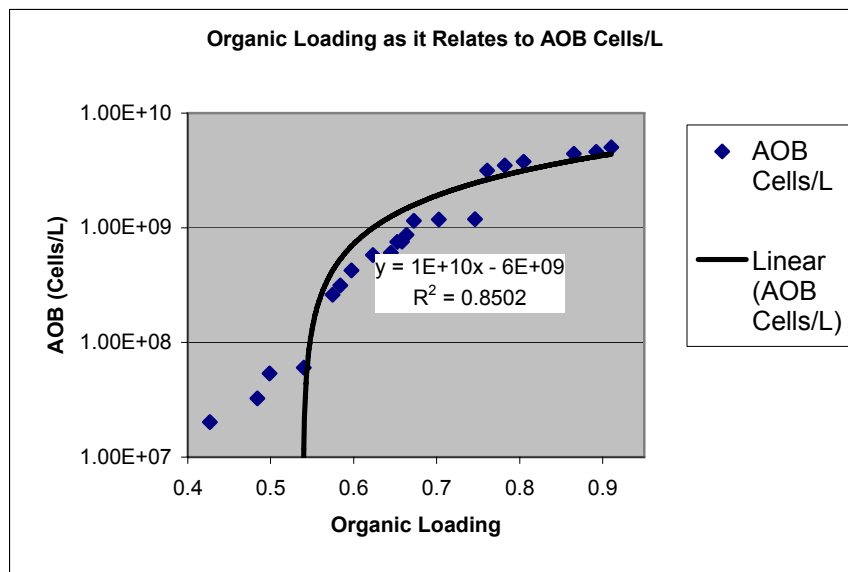

Figure 19: Secondary Effluent Turbidity as it Relates to AOB Cells/L at CWRP

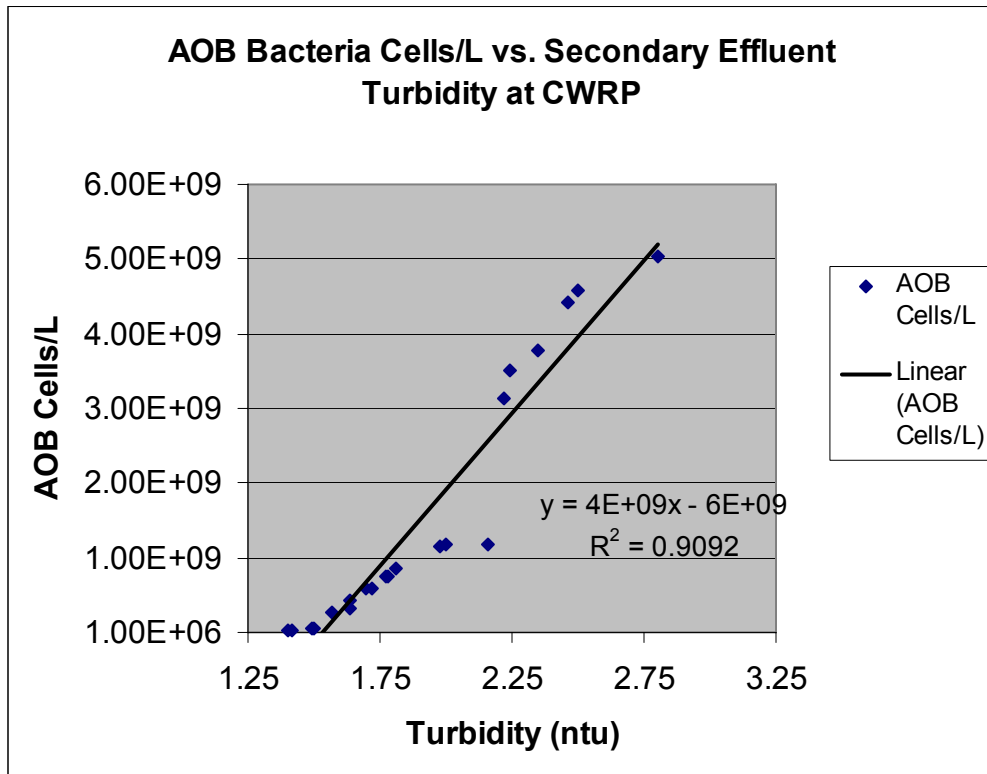

Figure 20: Flow (MGD) as it Relates to AOB at OCWRP

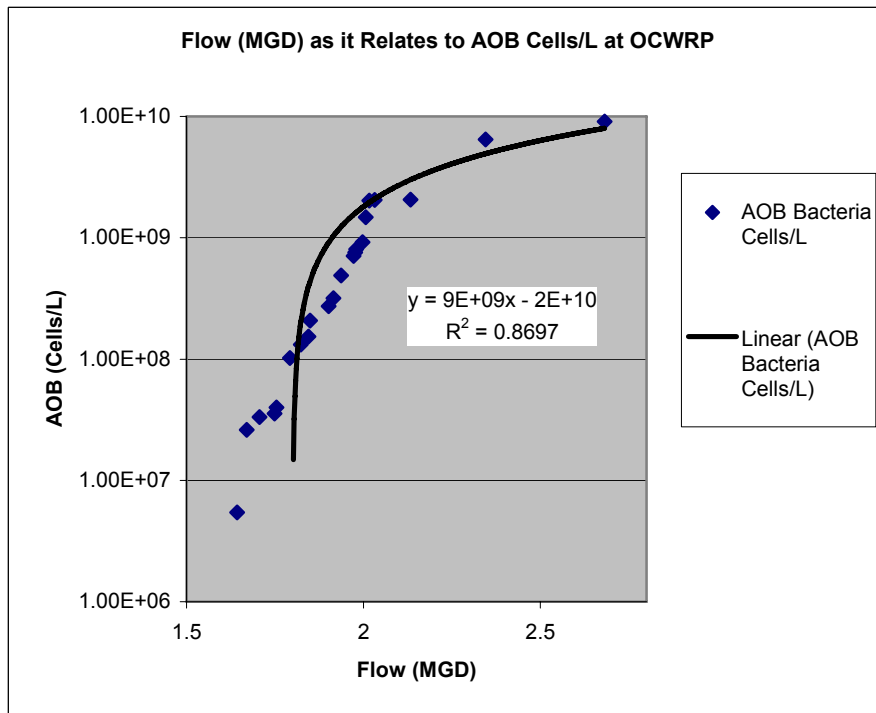



Figure 21: Ammonia Oxidation per cell per hour as a Function of AOB Cells/L at OCWRP

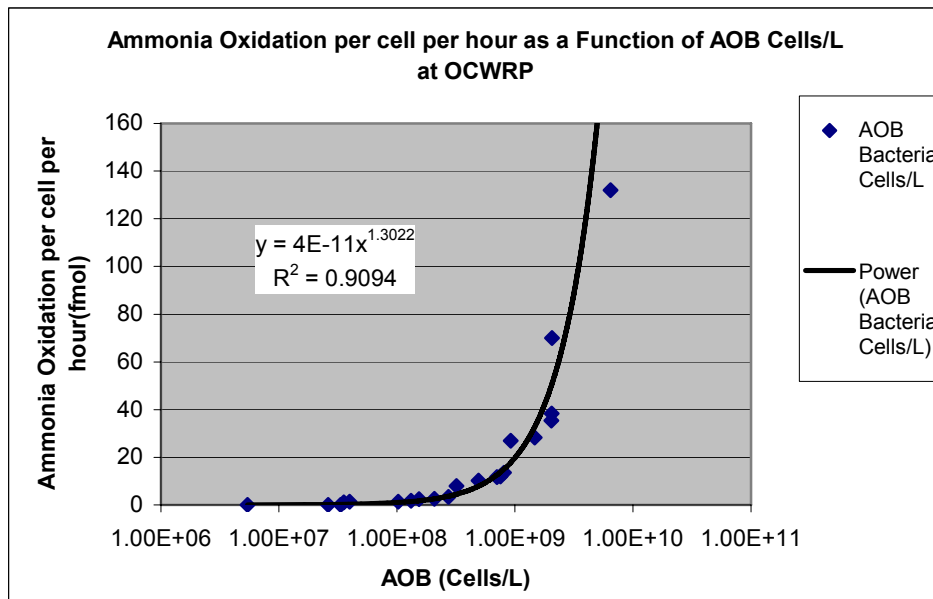

Figure 22: Effluent Nitrite Concentration as a function of AOB Cells/L at OCWRP

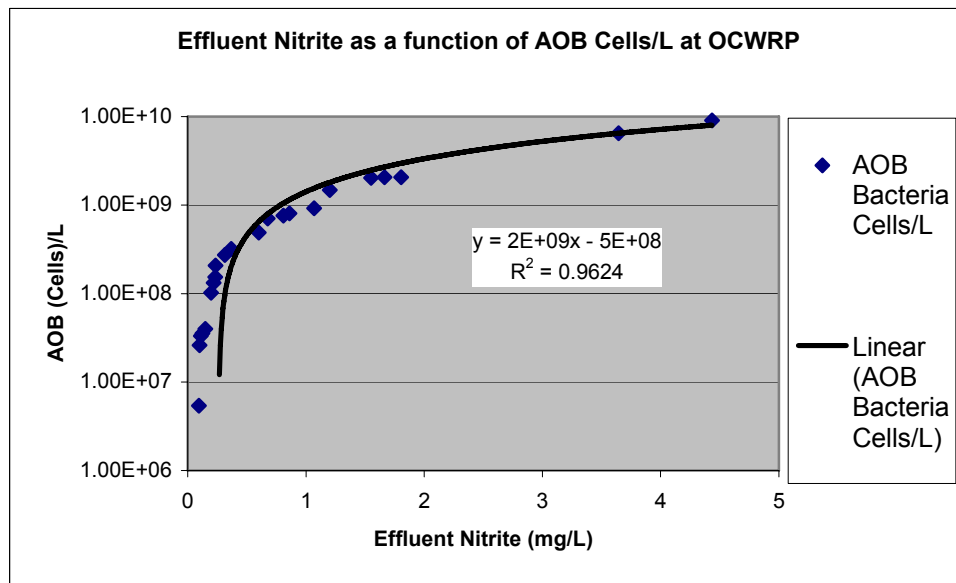

Figure 23: Detention Time as a Function of AOB Cells/L at OCWRP

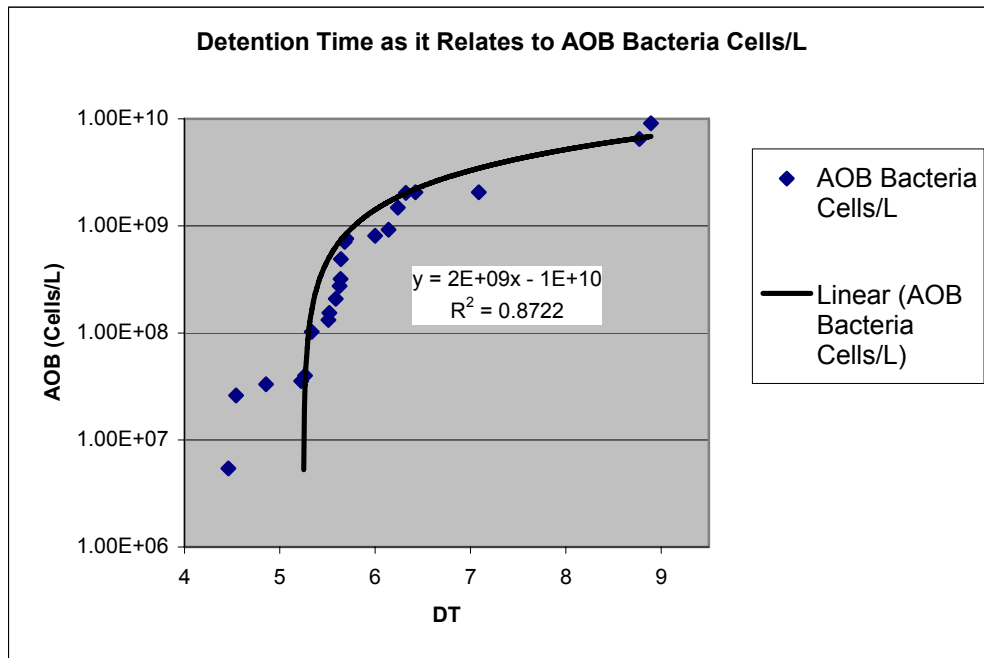

Figure 24: AOB Cells/L as a Function of Increased Secondary Turbidity at OCWRP

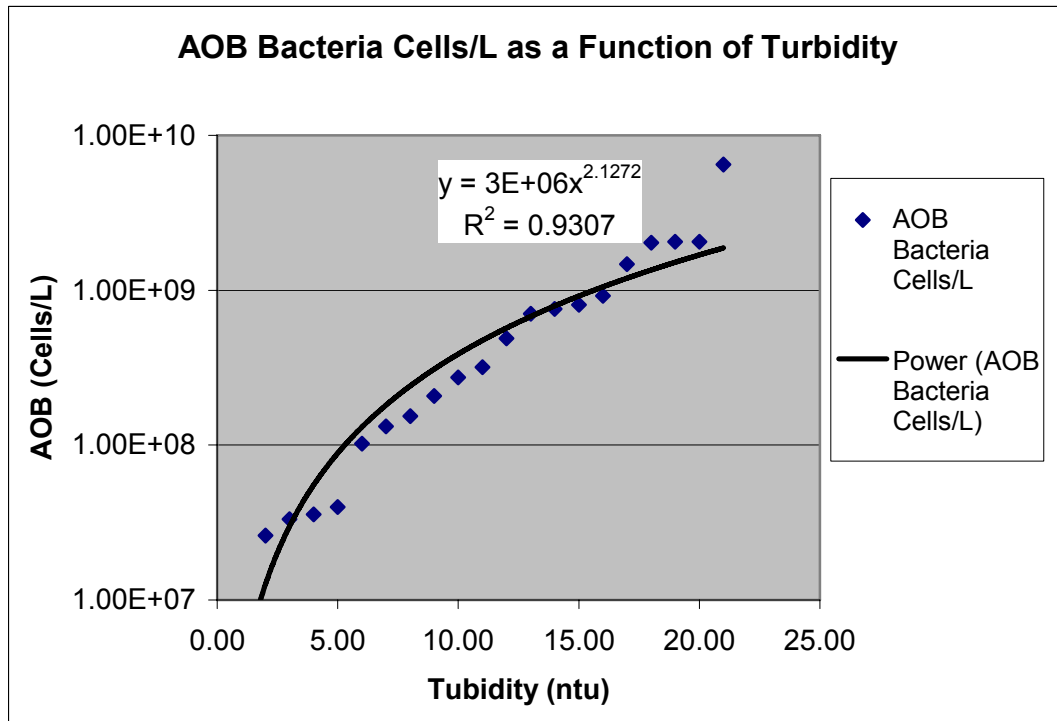

Figure 25: Operator Recorded SCFM as it Relates to AOB Cells/L and D.O.

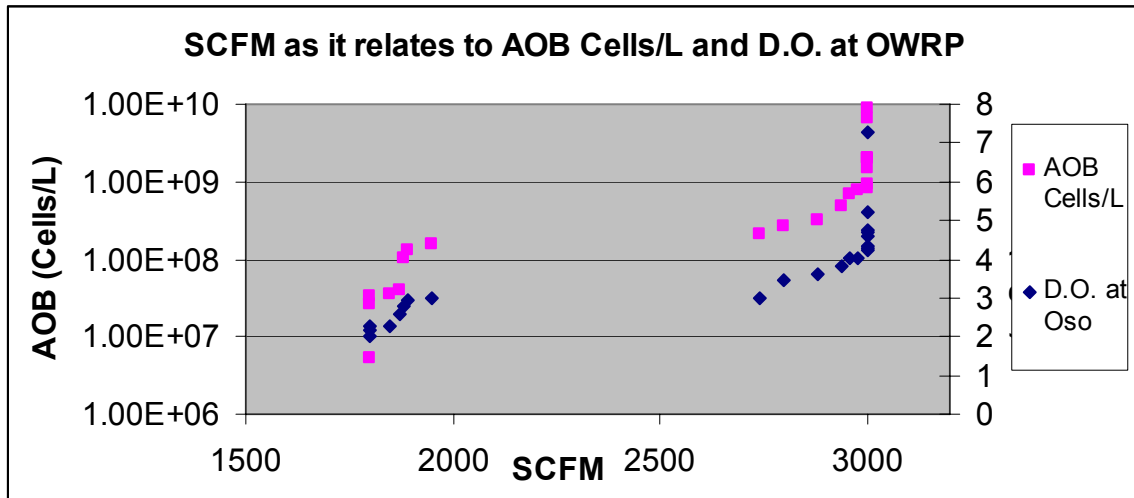

Figure 26: The relationship between SCFM, KW, and D.O. at CWRP

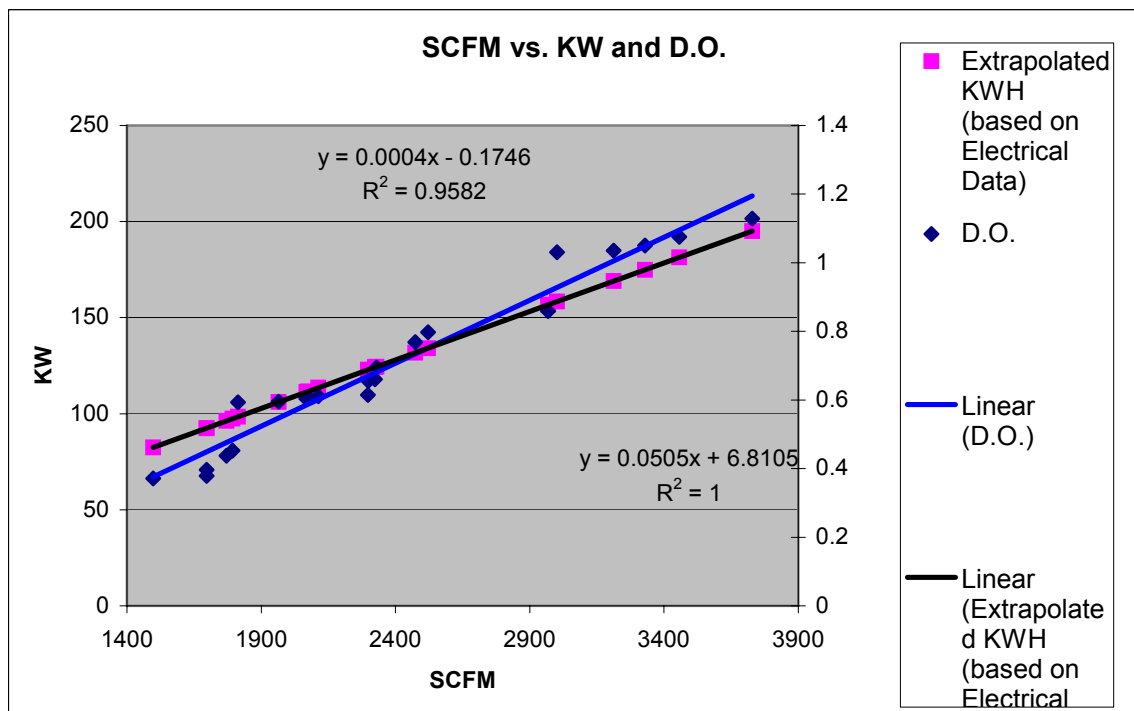
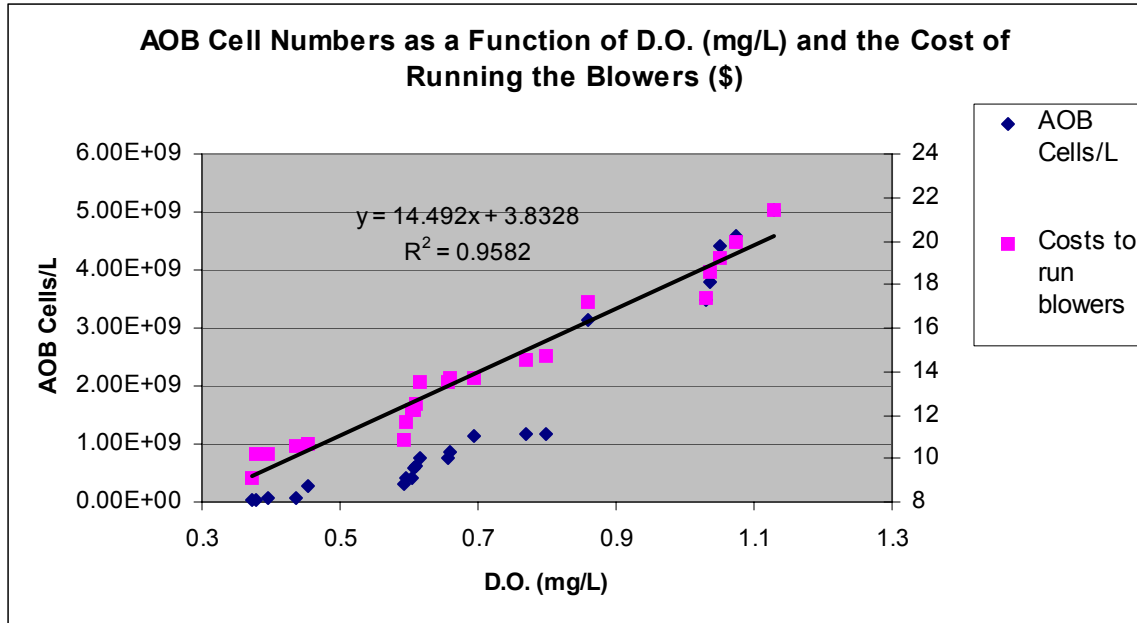

Figure 27: AOB Cells/L as a function of D.O. and the Cost of Running the Aeration Blowers at CWRP



## **Discussion:**

As the demand for recycled water increases, the quality of the water produced will most likely become more stringent. Predictive tools to discriminate how bacterial populations change the effluent water quality will need to be developed to meet this need in a timely manner. This study has sought to fill this gap so that the wastewater industry can become one step closer to face the challenges ahead. By utilizing qPCR, actual cell numbers per liter were obtained to deduce the makeup of the bacterial ecology in the aeration basin of the secondary treatment processes.

An analysis of the correct sample location, sample holding time and DNA extraction were evaluated in order to understand how each fits into the framework of real-world application. Table 2 proves that the combined flow of the aeration basin treatment trains have no significant difference in mixed liquor suspended solids and therefore no difference in AOB cell numbers since MLSS and AOB cells/L are strongly correlated (see below). The sample holding time method as expressed in the Limpiyakorn paper was evaluated to decipher if extra measures needed to be taken if a sample was not able to be analyzed immediately. Table 6 shows the values obtained in this experiment and indicate that the Limpiyakorn method should be utilized if a sample can not be analyzed upon collection. The removal of the second bead beating step was also tested (Figure 3) in order to minimize the time the analyst spends in this process thereby allowing the analyst to spend time in other procedures. Figure 3 shows that the second bead beating step should not be eliminated so that maximum DNA yield can be obtained.

As stated earlier, other researchers have found differing AOB populations at various treatment plants and so a gel was ran (Figure 4) with the specific primers and probes to assess if the target AOB were present in the two treatment plants. Amplification at the 116bp region confirmed the presence of the target group. This allowed for the qPCR to be performed with the primers and probes in Table 1.

The bacterial cell numbers were compared to analytical and operating parameters to assess if there were any direct relationships between the variables. Total bacteria cell numbers for CWRP were  $5.95 \times 10^9$ - $3.64 \times 10^{14}$ . The cells/L of AOB at CWRP were  $2.02 \times 10^7$ - $5.03 \times 10^9$ . The average percentage of AOB compared to total bacteria was 3.01%. The cells/L of total bacteria at OCWRP were  $1.32 \times 10^9$ - $4.13 \times 10^{14}$ . The cells/L of AOB at OCWRP were  $5.44 \times 10^6$ - $9.06 \times 10^9$ . The average percentage of AOB compared to total bacteria was 1.598%.

It is interesting to note that the cell numbers obtained at each treatment plant in this particular study were similar, with only a one log difference in AOB at OCWRP. However, the bacterial cell numbers in this study differed slightly from other studies that used the qPCR technique to quantify bacterial and AOB 16S cell numbers. Limpiyakorn *et.al.* evaluated 12 treatment plants in Tokyo and found total bacterial numbers and total AOB numbers in the range of  $1.6 \times 10^{12}$ - $2.4 \times 10^{13}$  and  $1.0 \times 10^9$ - $9.2 \times 10^{10}$ , respectively. The percentage of AOB in the 12 systems accounted for 0.01-2.8% of total bacterial population, agreeing with the results obtained in this study. The main difference between

the Limpiyakorn study is that all but one treatment plant evaluated had percent ammonia removal in the 95-99 percentile, whereas the CWRP ranged from 22-54% and the OCWRP ammonia removal differed between 21-82%. The fluctuations in ammonia removal could account for the large difference in AOB cell numbers since the two treatment plants studied are not adapted to complete nitrification.

Harms *et. al.* found  $4.3 \pm 2.0 \times 10^{11}$  and  $1.2 \pm 0.9 \times 10^{10}$  bacterial and AOB cells/L respectively in the secondary clarifier. Although this study employed the qPCR technique to evaluate 16S rRNA, the samples collected were from the up well of the secondary clarifier, thereby obfuscating a parallel relationship between this study and the Harms study. The Limpiyakorn and Harms studies were accomplished over a year period to deduce the population fluctuations apparent in differing seasonal conditions, taking only one sample per month. This study only evaluated the population dynamics over a two-month period using frequent sampling intervals of three times per week, which could explain the slight difference in cell numbers.

Table 6 shows the correlation coefficients between the variables. In an effort to discriminate between the correlation coefficients, a threshold value of 0.9 indicated that a strong relationship between the independent and dependent variables existed. The highlighted values are a reflection of this threshold. We found that AOB cell numbers had greater correlation to analytical and process parameters as compared to total cell numbers, therefore the extrapolation of the relationships between AOB cell numbers and the independent variables ensued.

This study builds upon work that first tied protozoan population to effluent quality when molecular tools were not yet available to decipher the true bacterial populations responsible for the shift in effluent quality. In 1968 Curds *et.al.* demonstrated that when six different treatment plants were operated without protozoans, the effluent produced was turbid and had a high concentration of BOD. This study showed that when AOB cells/L increased, the effluent total BOD increased (Figure 13) as well as the secondary effluent turbidity (Figure 19) at the CWRP. This relationship was only half true for the OCWRP, which showed that as AOB cells/L increased, the secondary effluent increased (Figure 24), but not as strong a relationship was found (0.88) between AOB and total effluent BOD (Table 6). This can also be seen in the strong relationship (0.92) between AOB and organic loading as seen in Figure 18.

The MLSS and AOB correlation was 0.94 for CWRP and 0.88 for OCWRP. The AOB are found solely on floc particles in the top 200um (Gieseke, 2001), which explains why secondary effluent turbidity and MLSS are strongly correlated to AOB cell numbers. The CWRP also had a strong relationship to the return activated sludge (RAS) rate (correlation of 0.92) probably for the same reason of where the AOB reside on the floc as well as the solids retention time needed to keep the AOB in the system due to the slow growth rate of the AOB (see Figure 11). Keeping the AOB cell numbers in a range will help the operational optimization of process parameters in order to ensure high quality treated recycled water.

The optimization of bacterial populations to process parameters continues to be an ever evolving process, and not just for AOB populations. Some researchers have looked to analyze large microbial communities and link the overall community structure to process parameters (Wagner, 2002; Yuan, 2002; Briones, 2003). This study is a departure from the above studies in that it has tried to link specific a specific bacterial group (AOB) to effluent water quality.

A recent paper by La Para and Ghosh (2006) sought to link AOB to effluent water quality. The researchers quantified AOB using the competitive PCR technique and this resulted in a relationship whereas as the AOB population increased, the total Kjeldhal nitrogen (TKN, the sum of ammonia and organic nitrogen) decreased. There was also a strong relationship to a decrease in wastewater temperature and an increase in TKN as the ammonia was not changed to nitrite or nitrate due to the temperature sensitivity of the AOB and NOB. This could be related to the minimum SRT needed to prevent washout of nitrifying bacteria as expressed in equation 8:

$$\text{mSRT (Days)} = 3.05 * 1.27^{(T (^{\circ}\text{C}) - 20)}; \text{ Where } T = \text{the temperature of the aeration basin MLSS}$$

Equation 8 shows the minimum SRT to prevent washout of AOB in the activated sludge process. Over the course of the experiment the CWRP when not meeting the minimum SRT functioned on average 26% less than the minimum SRT to prevent washout, while the OCWRP functioned at approximately 46% of the minimum SRT. Washout of AOB at certain times at certain times could be what helps these treatment plants maintain partial nitrification in order to meet permit requirements. This study might allow for better understanding of the minimum SRT required to prevent washout versus actual SRT to better control the system.

A question posed in the LaPara paper is whether an increase in AOB results in an increase in ammonia removal. The CWRP showed a strong relationship in the percentage of ammonia removed (0.91 correlation) and AOB numbers, as indicated in Graph 12. The OCWRP correlation was 0.86 indicating that there is a moderate relationship between AOB cells/L and ammonia removal at the OCWRP. The ammonia drop and percent ammonia removal across the aeration tank had a direct correlation to AOB cell numbers 0.92 & 0.91 respectively (Figures 14 & 15), whereas there was no such relationship found at the OCWRP. It is interesting to note that the conversion to nitrite was directly correlated (0.98) to AOB cell numbers at the OCWRP (Figure 22), while the conversion of ammonia correlation was found more strongly between nitrate and AOB cell numbers (0.98) at the CWRP (Figure 16).

The strongest relationship, as measured by the correlation value was ammonia oxidation per cell per hour and AOB cells/L at OCWRP. The mean AOB oxidation per cell per hour averaged 15.60 fmol with a range of 0.02-131.95 fmol at OCWRP and 39.76 fmol, with a range of 0.02-286.28 fmol at CWRP. The Harms study (2003) found  $7.7 \pm 6.8$  fmol/cell/hr in the AOB 16rDNA group. The large ranges apparent in the study resulted from the large 3-4 log AOB population variation in the two treatment plants.

The operational controls allow the wastewater treatment plant operators to control how the AOB respond in their environment. The operating parameter of detention time was found to be strongly correlated at both the AOB at the CWRP (0.92) and the OCWRP (0.93). These relationships can be seen in graphs 14 & 20 respectively. The author feels that this can be explained by the slow growth rate of AOB.

The operational controls that had the greatest effect in this study were flow at the OCWRP and dissolved oxygen at the CWRP. Incoming flow at the OCWRP cannot be controlled, especially since the OCWRP does not have a flow equalization basin, but the dissolved oxygen at the CWRP can be controlled through blower controlled set points as suggested by Senior Wastewater Treatment Operator (WTO) Carlos Aguirre. The SCFM (Standard Cubic Feet per Minute) set points, as controlled by the operators control the amount of dissolved oxygen entering the aeration tanks. The SCFM is a function of the volumetric flow rate of gas (atmospheric oxygen in this case) to standardized conditions of temperature, pressure, and relative humidity and translate to a precise mass flow rate ([www.engineeringtoolbox.com](http://www.engineeringtoolbox.com), 2007). Carlos suggested a program where a set point between 0.7 and 1.0 mg/L of dissolved oxygen would be chosen and the acceptable range of plus or minus 0.2 mg/L would be the bounding acceptable optimization range to control the corresponding SFCM. Implementation of this suggestion could help defray unnecessary costs related to blower output.

As stated earlier, one of the reasons that the CWRP and the OCWRP try to stay out of nitrification is the cost of the electricity to run the aeration blowers at dissolved oxygen values of 2.5mg/L or greater. To decipher the relationship between D.O., SCFM, and electricity usage (KW), the electricians performed a kilowatt step test. The results of that test can be seen in graph 23. The graph illustrates a direct relationship between all three parameters. The linear regression employed allow the operator to input SCFM values into the two equations to determine the corresponding D.O. or KW usage. The KW usage was tied directly into an energy value as a function of cost to be 0.11 cents per hour, and is illustrated in graph 24.

Dissolved oxygen is directly tied to AOB cell numbers and AOB cell numbers are directly correlated to secondary effluent turbidity, a measure of water quality produced, so by evaluating the cost of the electricity at the CWRP (as a function of SCFM) in KW an optimized range could be sought. The optimization of the above relationships can be seen in the following table:

Grouping	D.O. (mg/L)	SCFM	Costs/Hr (KWH)	AOB (Cells/L)	Turbidity (ntu)
1	0.4-0.5	1450-1799	9.07-10.81	2e7-2.61e8	1.4-1.5
2	0.51-0.9	1800-2999	10.82-17.44	2.62e8-3.14e9	1.51-2.16
3	0.91-1.2	3000-3800	17.45-21.45	3.15e9-5.03e9	2.17-2.8

Table 7: Optimization Variables at CWRP



The highlighted row is what the author feels is the optimal condition for process stability. The above table illustrates that when D.O. values are above 0.91mg/L to 1.2 mg/L, the corresponding cost results in \$17.45-21.45 per KWH. The cost for that electricity over the year in this category would be \$152,326-\$187,243. The cost per year of electricity in the second category is \$94,451-152,238. By staying in the second range the CWRP could save \$34,917 per year, a definite cost saving advantage.

By using the same optimal indicators as above, at OCWRP, unfortunately a direct relationship to SCFM and D.O. control was not found however, making an estimate of cost savings unfeasible. This is due to the fact that there is that there is precise blower control at the CWRP, making correct relationships feasible. But if one were to compare the optimal group 2 D.O. values for the CWRP of 0.51-0.9 mg/L versus group 3 D.O. values of 0.91-1.2 mg/L (table 7) and the optimal group 1 values of 1.9-3.0 mg/L versus the group 2 D.O. values at OCWRP (table 8), the cost savings to avoid venturing into the group two D.O. values would be quite tremendous. The problem at the OCWRP is the lack of dissolved oxygen control, therefore D.O. values can spike dramatically at low flow periods, causing an upset of microbial ecology. This could be the reason that there were not more direct relationships found at the OCWRP as compared to the CWRP.

Grouping	D.O. (mg/L)	SCFM	AOB (Cells/L)	Turbidity (ntu)
1	1.9-3.0	1800-1950	5.4 x 10 <sup>6</sup> -1.54 x 10 <sup>8</sup>	2.57-3.99
2	3.01-7.26	2740-3000	2.08 x 10 <sup>8</sup> -9.06 x 10 <sup>9</sup>	4.00-28.72

Table 8: Optimization Variables at OCWRP

On a final note, the effect that the AOB population has on chlorine usage was evaluated to determine if an increase in AOB cell numbers in the aeration basin has a direct effect on the chlorine usage at the CWRP, thereby directly affecting the cost of chlorine used. Gallons of bleach (hypochlorite – NaOCl ~12%) used per day ranged from 23 to 514 gallons per million gallons of reclaimed water produced. The correlation between the two parameters was found to be 0.72, indicating that the two parameters are not strongly related. A study to assess direct relationship of chlorine and AOB would need to evaluate AOB populations at the beginning and end of the chlorine contact basin.

## **Conclusion:**

It must be stressed in this project that the results obtained were only over the winter season in Southern California and for a more accurate analysis a longer period must be analyzed to understand how different seasonal fluctuations affect the actual populations. Although the samples taken were taken at the same time each day, three times per week, including weekends allowing establishment of constant conditions (the control), the diurnal pattern was not analyzed, so fluctuations in populations as they wash out of the system should also be studied to gauge how the population changes at various times of the day. Although Curtis and Crane (1998) did not find within site temporal variations as a function of bacterial population stability, their study did not focus solely on one specific bacterial population. LaPara *et. al.* (2006) found that the AOB populations, as evaluated by *amoA* gene fragments, varied more than eightfold throughout the year, stressing the need for a more complete study to decipher population dynamics throughout the year.

This study sought to link water quality parameters to AOB using new rapid detection techniques emerging in the wastewater industry. The author found a very strong relationship between the AOB and secondary effluent turbidity at both treatment plants studied, which emphasizes the integral role that the AOB play in the production of recycled water. It is the author's conclusion that by controlling the AOB by operational controls, the production of recycled water can be optimized to meet increased demand and water quality parameters.

## **Acknowledgements:**

I would like to sincerely thank laboratory personnel Jim Pulles and Minh Nguyen. I would also like to thank Bob Jordan and Dr. Betty Olson for their guidance and support throughout the project. The help from Dr. Olson's graduate student Phil Gedalanga was also paramount to the completion of the molecular portion of the project. The cooperation of electrical and operating staff was integral in the completion of this project. I would finally like to thank the support received from the Santa Margarita Water District, for making this project feasible.

## **Works Cited**

- Akara, A.; Utaker, J.B.; Nes, I. F. 1999. RFLP of rRNA genes and sequencing of the 16S-23S rDNA intergenic spacer region of ammonia-oxidizing bacteria: a phylogenetic approach. *International Journal of Systematic Bacteriology*. 49: 123-130.
- Alexander M. 1982. Most probable number method for microbial populations. *Methods of Soil Analysis*. Second Edition. Pp.815-20. Madison, WI: Am. Soc. Agron.
- Ballinger, S.J., Head, I.M., Curtis, T.P., and Godley, A.R. (1998) Molecular microbial ecology of nitrification in an activated sludge process treating refinery wastewater. *Water Sci. Tech.* 37, 105-108.
- Bergey's Manual of Systematic Bacteriology; Second Edition. Volume Two: The Proteobacteria. 2005, 1984-1989 Bergey's Manual Trust, Springer pp.137-147.
- Bjerrum, L., T. Kjaer, N.B. Ramsing. 2002. Enumerating ammonia-oxidizing bacteria in environmental samples using competitive PCR. *J. of Microbiol. Methods*. 51:227-239.
- Both, G.J., S. Gerards, & H.J. Laanbroek. 1990. Enumeration of nitrite oxidizing bacteria in grassland soil using a most probable number technique: effect of nitrite concentration and sample procedure. *FEMS Microbiol. Ecol.* 74:277-286
- Bourrain, M.; Achouak, W.; Urbain, V.; Heulin, T. (1999). DNA Extraction from Activated Sludges. *Current Microbiology*. Vol. 38:315-319.
- Briones, A.; Raskin, L. (2003) Diversity and dynamics of microbial communities in engineered environments and their implications for process stability. *Current Opinion in Biotechnology*. 14:270-276.
- Burian, Steven, Nix, Stephen J., Pitt, Robert E., & Durrans, Rocky S. Urban Wastewater Management in the United States: Past, Present, & Future. *Journal of Urban Technology*. 2000. Volume 7, Number 3, pp.33-62.
- Calvo, L.; Garcia-Gil, J.L. 2004. Use of *amoB* as a new molecular marker for ammonia-oxidizing bacteria. *J. of Microbiol. Methods*. 57:69-78.
- Culp, R.L., Wesner, G.M. and Culp, G.L. (1978) *Handbook of Advanced Wastewater Treatment* (2<sup>nd</sup> Ed.). Van Nostrand Reinhold, New York.
- Curds, C.R.; Cockburn, A.; Van Dyke, J.M. (1968) An experimental study of the role of ciliated protozoa in the activated sludge process. *Water Pollution Control*. 67: 312-29.
- Curtis, T.P. and Craine, N.G. (1998) The Comparison of the Diversity of Activated Sludge Plants. *Wat. Sci. Tech.* 37:71-78.
- Daims, H.; Ramsing, N.B.; Schleifer, K-H; Wagner, M. Cultivation-Independent, Semi-automatic Determination of Absolute Bacterial Cell Numbers in Environmental Samples by Fluorescent In Situ Hybridization. *Applied and Environmental Microbiology*. 67:5810-5818.
- De Boer W, Klein-Gunnewiek PJA, Troelstra SR. 1990. Nitrification at low pH by aggregated autotrophic bacteria. *Appl. Environ. Microbiol.* 57: 3600-4.
- Degrange, V. and R. Bardin. 1995. Detection and counting of *Nitrobacter* populations in soil by PCR. *Appl. and Environ. Microbiology*. 61:2093-2098

Dionisi, H.M., *et.al.* 2002. Quantification of *Nitrosomonas oligotropha*-Like Ammonia-Oxidizing Bacteria and *Nitrospira* spp. From Full-Scale Wastewater Treatment Plants by Competitive PCR. *Appl. and Environ. Microbiology*. 68:245-253.

EPA's Environmental Fact Sheet for Groundwater and Drinking Water. Based on National Primary Drinking Water Standards. Updated November 28, 2006. URL: <http://www.epa.gov/OGWDW/dwh/c-ioc/nitrates.html>

Erwin, D.P.; Erickson, I.K.; Delwiche, M.E.; Colwell, F.S.; Strap, J.L.; Crawford, R.L. 2005. Diversity of Oxygenase Genes from Methane- and Ammonia-Oxidizing Bacteria in the Eastern Snake River Plain Aquifer. *Appl. and Environ. Microbiol.* 71:2016-2025.

(FWPCA-a) Federal Water Pollution Control Act of 1972.s 101(1)

(FWPCA-b) Federal Water Pollution Control Act of 1972.Current Amendments through 2002. Title II. s 201(3)(d)

Gieseke, A.; Rurkhold, E.; Wagner, M.; Amann, R.; Schramm, A. (2001). Community Structure and Activity Dynamics of Nitrifying Bacteria in Phosphate-Removing Biofilm. *Appl. and Environ. Microbiol.* 67: 1351-62.

Gray, N.F. (2004). *Biology of Wastewater Treatment*, Vol. 4. Imperial College Press; London, England.

Harms, G.;Layton, A.C.; Dionisi, H.M.; Gregory, I.R.; Garrett, V.M.; Hawkins, S.A.; Robinson, K.G.; and Saylor, G.S. (2003) Real-time PCR quantification of nitrifying bacteria in a municipal wastewater treatment plant. *Environ. Sci. Tech.* 37, 343-351.

Hermansson, A. and Lindgren, P-E. 2001. Quantification of Ammonia-Oxidizing Bacteria in Arable Soil by Real-Time PCR. *Appl. and Environ. Microbiol.* 67:972-976.

Hiorns, W.D., Hastings, R.C., Head, I.M., McCarthy, A.J., Saunders, J.R., Pickup, R.W., and Hall, G.H. (1995) Amplification of 16S Ribosomal RNA genes of autotrophic ammonia-oxidising bacteria demonstrates the ubiquity of *Nitrosospira* in the environment. *Microbiology* 141, 2793-2800.

Holland, P.M.; Abramson, R.D.; Watson, R.; Gelfand, D.H. (1991) Detection of specific polymerase chain reaction product by utilizing the 5'-3' exonuclease activity of *Thermus aquaticus*. *Proc. Natl. Acad. Sci. USA.* 88:7226-7280.

Holmes, A.J.; Costello, A.;Lidstrom M.E.; Murrell, J.C. 1995. Evidence that particulate methane monooxygenase and ammonia monooxygenase may be evolutionary related. *FEMS Microbiol Ecol.* 132:203-208.

Hooper, A.B. 1984. Ammonia oxidation and energy transduction in nitrifying bacteria. Strohl and Tuovinen (Editors), *Microbial Chemosutography*, Ohio State University Press, Columbus. 133-167.

Hooper, A., Vannelli, T. Bergmann, D. and Arciero, D. 1997. Enzymology of the oxidation of ammonia to nitrite by bacteria. *Antonie Van Leeuwenhoek* 71:59-67.

Juretschko, Stefan, *et. al.* 1998. Combined Molecular and Conventional Analyses of Nitrifying Bacterium Diversity in Activated Sludge: *Nitrosococcus mobilis* and *Nitrospira*-Like Bacteria as Dominant Populations. *Applied and Environmental Microbiology.* p.3042-3051.

Koops, H.P.; Pommerening-Roser, A. 2001. Distribution and ecophysiology of the nitrifying bacteria emphasizing cultured species.

- Kowalchuk, G.A., J.R. Stephen, E.De Boer, J.I. Prosser, T.M. Embley and J.W. Woldendorp. 1997. Analysis of ammonia-oxidizing bacteria of the beta subdivision of the class *Proteobacteria* in coastal sand dunes by denaturing gradient gel electrophoresis and sequencing of PCR amplified 16S ribosomal DNA fragments. *Appl. Environ. Microbiol.* 63:1489-1497.
- Kowalchuk, G.A., Steinstra, A.W., Heilig, G.H.J., Stephen, J.R., and Woldendorp, J.W. (2000) Molecular analysis of ammonia-oxidizing bacteria in soil of successional grasslands of the Drentsche A (The Netherlands). *FEMS Microbiol. Ecol.* 31, 207-215.
- Kowalchuk, G.A., Stephen, J.R. (2001). Ammonia-Oxidizing Bacteria: A Model for Molecular Microbial Ecology. *Annual Rev. Microbiol.* 55:485-529.
- Limpiyakorn, T.; Shinohara, Y.; Kurisu, F.; Yagi, O. (2005). Communities of ammonia-oxidizing bacteria in activated sludge of various sewage treatment plants in Tokyo. *FEMS Microbiology Ecology.* 54:205-217.
- LaPara, Timothy, M. & Ghosh, Sudeshna. 2006. Population Dynamics of the Ammonia-Oxidizing Bacteria in a Full-Scale Municipal Wastewater Treatment Facility. *Environmental Engineering Science.* Volume 23, No. 2. pp. 309-317
- Matulewich, V.A., P.F. Strom and M.S. Finstein. 1975. Length of incubation for enumerating nitrifying bacteria present in various environments. *Appl. Microbiol.* 29:265-268.
- McCaig, A.E., T.M. Embley and J.I. Prosser. 1994. Molecular Analysis of enrichment cultures of marine ammonia oxidizers. *FEMS Microbiol. Letters.* 120: 363-367
- Mendum, T.A.; Sockett, R.E., Hirsch, P.R. 1999. Use of molecular and isotopic techniques to monitor the response of autotrophic ammonia-oxidizing populations of the Beta-subdivision of the class *Proteobacteria* in arable soils to nitrogen fertilizer. *Appl. Environ. Microbiol.* 65:4155-62.
- Mobarry, B.K., Wagner, M. Urbain, V., Rittman, B.E. and Stahl, D.A. (1996) Phylogenetic probes for analyzing abundance and spatial organization of nitrifying bacteria. *Appl. Environ. Microbiol.* 62, 2156-2162.
- Mumy, K.L., Findlay, R.H. 2004. Convenient determination of DNA extraction efficiency using an external DNA recovery standard and quantitative-competitive PCR. *Journal of Microbiol. Methods.* 57:259-268.
- Nelson, D.L. & Cox, M.M. Lehninger: Principles of Biochemistry. 2003. Third Edition. Worth Publishers. pp.1072-1081.
- Norton, J.M., Alzerreca, J.J., Suwa, Y., Klotz, M.G., 1996. Diversity of ammonia monooxygenase operon in autotrophic ammonia-oxidizing bacteria. *Arch. Microbiol.* 177, 139-149.
- Norton, J.M., Low, J.M., Klotz, M.G. 2000. The gene encoding ammonia monooxygenase subunit A exists in nearly three copies in *Nitrosospora* sp.NpAV. *FEMS Microbiol. Letters.* 139, 181-188.
- Picard, C.; Ponsonnet, C.; Paget, E.; Nesme, X.; Simonet, P. 1992. Detection and enumeration of soil by direct DNA extraction and polymerase chain reaction. *Appl. Environ. Microbiol.* 58:2717-2722.
- Purkhold, et. al. 2000. Phylogeny of All Recognized Species of Ammonia Oxidizers Based on Comparative 16SrRNA and *amoA* Sequence Analysis: Implications for Molecular Diversity Surveys. *Applied and Environmental Microbiology.* Vol. 66, No. 12:5368-5382
- National Academy of Sciences (NAS). 1995. Nitrate and Nitrite in Drinking Water. National Research Council. National Academy Press.

- Rowan, A.K., Snape, J.R., Fearnside, D., Barer, M.R., Curtis, T.P., & Head, I. M.. (2003). Composition and diversity of ammoni-oxidising bacterial communities in wastewater treatment reactors of different design treating identical wastewater. *FEMS, MicrobiologyEcology*. 43: 195-206.
- Rotthauwe, Jan-Henrich, Witzel, Karl-Paul, Liesack. 1997. The Ammonia Monooxygenase Structural Gene *amoA* as a Functional Marker: Molecular Fine-Scale Analysis of Natural Ammonia Oxidizing Populations. *Applied and Environmental Microbiology*. Vol. 63, No.12: 4701-4712.
- Sayavedra-Soto, L.A., N.G. Hommes, J.J. Alzereca, D.J. Arp, J.M. Norton, and M.G. Klotz. 1998. Transcription of the *amoC*, *amoA*, and *amoB* genes in *Nitrosomonas europaea* and *Nitrospira* sp. NpAV. *FEMS Microbiology Letters* 167:81-88.
- Schramm, A.; de Beer, D.; van den Heuvel, J.; Ottengraf, S.; Amann, R. 1999. Microscale Distribution of Populations and Activities of *Nitrospira* and *Nitrosospira* spp. along a Macroscale Gradient in Nitrifying Bioreactor: Quantitation by In Situ Hybridization and Use of Microsensors. *Applied and Environmental Microbiology*.65:3690-3696.
- Sinigalliano, C.D.; Kuhn, D. N.; Jones, R.D. 1995. Amplification of the *amoA* Gene from Diverse Species of Ammonium-Oxidizing Bacteria and from and Indigenous Bacterial Population from Seawater. *Appl. and Environ. Microbiol.* 61:2702-2706.
- SM (2005), *Standard Methods for the Examination of Water and Wastewater*. Twenty-First Edition. American Public Health Association (APHA), American Water Works Association (AWWA) & Water Environment Federation (WEF); Alexandria, Virginia.
- Speksnijder, A.G., G.A. Kowalchuck, K. Roest, and H.J. Laanbroek. 1998 Recovery of *Nitrosomonas*-like 16S rDNA sequence group from freshwater habitats. *Syst. Appl. Microbiol.*21:321-330.
- Stephen, J.R., A.E. McCaig, A. Smith, J.I. Prosser and T.M. Embley. 1996. Molecular diversity of soil and marine 16SrRNA gene sequences related to  $\beta$ -subgroup ammonia-oxidizing bacteria. *Applied Environ. Microbiol.* 62:4147-4154.
- STR (Short Technical Reports) 1997. Quantitative Analysis of 16S rDNA Using Competitive PCR and the QPCR System 5000. *Biotechniques*. 22: 700-704.
- Suzuki, I.; Dular, U.; Kwok, S.C. (1974) Ammonia or Ammonium Ion as Substrate for Oxidation by *Nitrosomonas europea* Cells and Extracts. *J. of Bacteriology, American Society for Microbiology*. p. 556-558.
- Suzuki, I. 1984. Oxidation of inorganic nitrogen compounds. Crawford and Hanson (editors). *Microbial growth on C<sub>1</sub> Compounds*. American Society for Microbiology. Washington, DC. pp.42-52.
- Tsai, Yu-Li and Olson, Betty H. (1991). Rapid Method for Direct Extraction of DNA from Soil and Sediments. *Applied and Environmental Microbiology*. 1991:1070-1074.
- Wagner, M., Rath, G., Amann, R., Koops, H.P. and Chleifer, K.H. (1995) In situ identification of ammonia-oxidising bacteria. *Syst. Appl. Microbiol.* 18, 251-264.
- Wagner, M.; Loy, A. (2002) Bacterial community composition and function in sewage treatment systems. *Current Opinion in Biotechnology*. 13:218-227.
- Water Pollution Control Legislation. University of California, Division of Agriculture and Natural Resources, Farm Water Quality Planning (FWQP). Publication 8088, FWQP Reference Sheet 8.1. 2003.
- Woese C, Fox G (1977). "Phylogenetic structure of the prokaryotic domain: the primary kingdoms.". *Proc Natl Acad Sci U S A* 74 (11): 5088-90.

Wood, P.M., 1986. Nitrification as a bacterial energy source. Prosser (Editor), Nitrification, IRL Press, Oxford. pp.39-62.

Yu, Zhongtang & William W. Mohn. 1999. Killing two birds with one stone: simultaneous extraction of DNA and RNA from activated sludge biomass. *Can. J. Microbiol.* 45:269-272.

Yuan, Z.; Blackall, L.L. (2002) Sludge population optimization: a new dimension for the control of biological wastewater treatment systems. *Water Research.* 36:482-490.